

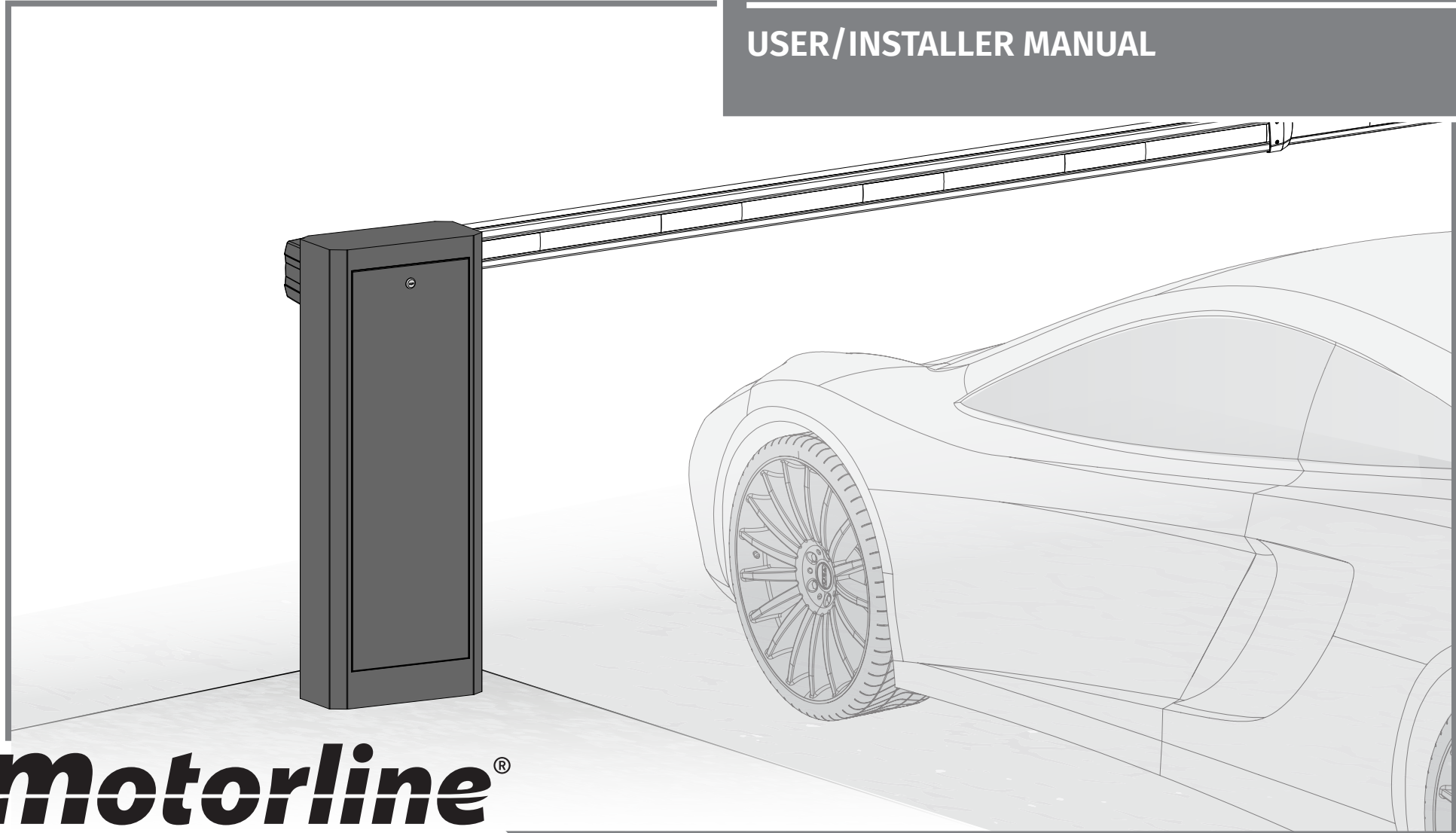

USER/INSTALLER MANUAL



00. CONTENT

INDEX







01. SAFETY INSTRUCTIONS	1B
02. AUTOMATISM	
TECHNICAL CHARACTERISTICS	4A
COMPATIBLE COMPONENTS	4B
DIMENSIONS	5A
03. INSTALLATION	
INSTALLATION AND ADJUSTING PROCESS	5B
INSTALLATION MAP EXAMPLE	6
DOOR OPENING	7A
MANUALLY MOVE THE BOOM	7A
AUTOMATION INSTALLATION	7B
POWER CABLE	8
BOOM ASSEMBLY	9
FIX BOOM SUPPORTS (OPTIONAL)	10
REVERSE BOOM POSITION SX-DX	11
TUNE SPRING	12
TEST SPRING ADJUSTMENT	13A
TUNING TABLE	13B
04. CONNECTIONS	
CONNECTION DIAGRAM TURBO LITE - MC90BL-BR-TUR	15
CONNECTION DIAGRAM TURBO - MC90BL-BR-TUR	16
CONNECTION DIAGRAM - MM90-RGB MODULE (OPTIONAL)	17A
CONNECTION DIAGRAM - MASTER/SLAVE (OPTIONAL)	17B
05. TROUBLESHOOTING	
INSTRUCTIONS FOR END CONSUMERS / SPECIALIZED TECHNICIANS	18
06. MAINTENANCE	
MAINTENANCE TASKS AND FREQUENCY	19

 EN12453

This equipment complies with the requirements of standard EN 12453:2017+A1:2021 - Motorised doors and gates - Safety in use - Requirements for operating forces.

WARNING: Ensure that the impact force values measured at the points defined by EN 12445 are lower than the limits established by EN 12453.
Incorrectly setting the sensitivity of the obstacle detection system can pose a serious risk of harm to people, animals or objects.

01. SAFETY INSTRUCTIONS

	This product is certified in accordance with European Community (EC) safety standards.
	This product complies with Directive 2011/65/EU of the European Parliament and of the Council, of 8 June 2011, on the restriction of the use of certain hazardous substances in electrical and electronic equipment and with Delegated Directive (EU) 2015/863 from Commission.
	(Applicable in countries with recycling systems). This marking on the product or literature indicates that the product and electronic accessories (eg. Charger, USB cable, electronic material, controls, etc.) should not be disposed of as other household waste at the end of its useful life. To avoid possible harm to the environment or human health resulting from the uncontrolled disposal of waste, separate these items from other types of waste and recycle them responsibly to promote the sustainable reuse of material resources. Home users should contact the dealer where they purchased this product or the National Environment Agency for details on where and how they can take these items for environmentally safe recycling. Business users should contact their vendor and check the terms and conditions of the purchase agreement. This product and its electronic accessories should not be mixed with other commercial waste.
	This marking indicates that batteries should not be discarded like other household waste at the end of their useful life. Batteries must be delivered to selective collection points for recycling.
	The different types of packaging (cardboard, plastic, etc.) must be subject to selective collection for recycling. Separate packaging and recycle it responsibly.
	This marking indicates that the product and electronic accessories (eg. charger, USB cable, electronic material, controls, etc.) are susceptible to electric shock by direct or indirect contact with electricity. Be cautious when handling the product and observe all safety procedures in this manual.

01. SAFETY INSTRUCTIONS

GENERAL WARNINGS

- This manual contains very important safety and usage information. Read all instructions carefully before beginning the installation/usage procedures and keep this manual in a safe place that it can be consulted whenever necessary.
- This product is intended for use only as described in this manual. Any other enforcement or operation that is not mentioned is expressly prohibited, as it may damage the product and put people at risk causing serious injuries.
- This manual is intended firstly for specialized technicians, and does not invalidate the user's responsibility to read the "User Norms" section in order to ensure the correct functioning of the product.
- The installation and repair of this product may be done by qualified and specialized technicians, to assure every procedure are carried out in accordance with applicable rules and norms. Nonprofessional and inexperienced users are expressly prohibited of taking any action, unless explicitly requested by specialized technicians to do so.
- Installations must be frequently inspected for unbalance and the wear signals of the cables, springs, hinges, wheels, supports and other mechanical assembly parts.
- Do not use the product if it is necessary repair or adjustment is required.
- When performing maintenance, cleaning and replacement of parts, the product must be disconnected from power supply. Also including any operation that requires opening the product cover.
- The use, cleaning and maintenance of this product may be carried out by any persons aged eight years old and over and persons whose physical, sensorial or mental capacities are lower, or by persons without any knowledge of the product, provided that these are supervision and instructions given by persons with experienced in terms of usage of the product in a safe manner and who understands the risks and dangers involved.

- Children shouldn't play with the product or opening devices to avoid the motorized door or gate from being triggered involuntarily.
- If the power cable is damaged, it must be replaced by the manufacturer, after-sales service or similarly qualified personnel to avoid danger.
- The device must be disconnected from the electrical network when removing the battery.
- Ensure that blocking is avoided between the actuated part and its fixed parts due to the opening movement of the actuated part.

WARNINGS FOR TECHNICIANS

- Before beginning the installation procedures, make sure that you have all the devices and materials necessary to complete the installation of the product.
- You should note your Protection Index (IP) and operating temperature to ensure that is suitable for the installation site.
- Provide the manual of the product to the user and let them know how to handle it in an emergency.
- If the automatism is installed on a gate with a pedestrian door, a door locking mechanism must be installed while the gate is in motion.
- Do not install the product "upside down" or supported by elements do not support its weight. If necessary, add brackets at strategic points to ensure the safety of the automatism.
- Do not install the product in explosive site.
- Safety devices must protect the possible crushing, cutting, transport and danger areas of the motorized door or gate.
- Verify that the elements to be automated (gates, door, windows, blinds, etc.) are in perfect function, aligned and level. Also verify if the necessary mechanical stops are in the appropriate places.
- The control board must be installed on a safe place of any fluid (rain, moisture, etc.), dust and pests.
- You must route the various electrical cables through protective tubes, to protect them against mechanical exertions, essentially on

01. SAFETY INSTRUCTIONS

the power supply cable. Please note that all the cables must enter the control board from the bottom.

- If the automatism is to be installed at a height of more than 2,5m from the ground or other level of access, the minimum safety and health requirements for the use of work equipment workers at the work of Directive 2009/104/CE of European Parliament and of the Council of 16 September 2009.
- Attach the permanent label for the manual release as close as possible to the release mechanism.
- Disconnect means, such as a switch or circuit breaker on the electrical panel, must be provided on the product's fixed power supply leads in accordance with the installation rules.
- If the product to be installed requires power supply of 230Vac or 110Vac, ensure that connection is to an electrical panel with ground connection.
- The product is only powered by low voltage safety with control board (only at 24V motors).
- Parts/products weighing more than 20 kg must be handled with special care due to the risk of injury. It is recommended to use suitable auxiliary systems for moving or lifting heavy objects.
- Pay special attention to the danger of falling objects or uncontrolled movement of doors/gates during the installation or operation of this product.

WARNINGS FOR USERS

- Keep this manual in a safe place to be consulted whenever necessary.
- If the product has contact with fluids without being prepared, it must immediately disconnect from the power supply to avoid short circuits, and consult a specialized technician.
- Ensure that technician has provided you the product manual and informed you how to handle the product in an emergency.
- If the system requires any repair or modification, unlock the automatism, turn off the power and do not use it until all safety

conditions have been met.

- In the event of tripping of circuits breakers or fuse failure, locate the malfunction and solve it before resetting the circuit breaker or replacing the fuse. If the malfunction is not repairable by consult this manual, contact a technician.
- Keep the operation area of the motorized gate free while the gate in in motion, and do not create strength to the gate movement.
- Do not perform any operation on mechanical elements or hinges if the product is in motion.

RESPONSABILITY

- Supplier disclaims any liability if:
 - Product failure or deformation result from improper installation use or maintenance!
 - Safety norms are not followed in the installation, use and maintenance of the product.
 - Instructions in this manual are not followed.
 - Damaged is caused by unauthorized modifications
 - In these cases, the warranty is voided.

MOTORLINE ELECTROCELOS SA.

Travessa do Sobreiro, nº29
4755-474 Rio Côvo (Santa Eugénia)
Barcelos, Portugal

SYMBOLS LEGEND:



• Important safety notices



• Useful information



• Programming information



• Potentiometer information



• Connectors information



• Buttons information

02. AUTOMATISM

TECHNICAL CHARACTERISTICS

TURBO barriers are designed for access control in garages and parking lots. Perfect running performance, achieved by electronic speed control and optimized mechanics to protect the motor and gear. An efficient drive concept with a powerful 24Vdc BLDC gear and robust components guarantee intensive operation with a 100% working cycle.

TURBO offers an extendable boom that can change the opening time with different lengths, as well as accessories suitable for different purposes, for example, LED lighting on the boom and safety devices.



The operational forces of the barriers are certified according to EN 12453. Automatic obstacle detection provides additional safety. The boom automatically opens and reverses if an obstacle is encountered; This ensures that vehicles will never get stuck.

Technical specifications of the automation:

	TURBO	TURBO LITE
• RGB LED on top	Yes	No
• Boom with LED	Yes	No
• Power	150W	
• Barrier power supply	110/230Vac~ 50/60Hz	
• Motor voltage	24Vdc=	
• Noise	LpA <= 50dB (A)	
• Working temperature	-25°C to 55°C	
• Protection class	IP54	
• Working frequency	55%	
• Maximum daily manoeuvres	4000	
• Maximum boom length	6 meters	
• Motor type	Brushless	
• Control board	MC90BL-BR	
• Mounting type	Right and Left	
• Opening/Closing time	1,5 to 5 seconds *	
• Mechanism Torque	120Nm (max)	
• Mechanism Rotation Speed	8 rpm (max)	
• Motor Rotation Speed	1800 rpm	
• Weight	51 kg	

*Opening time varies depending on boom length

02. AUTOMATISM

COMPATIBLE COMPONENTS

• LED Flashing Light
Only in the TURBO version

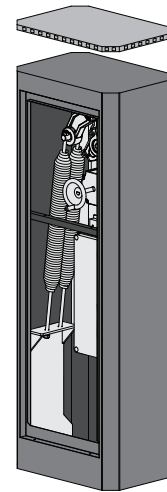

• Barrier
(Control board inside)

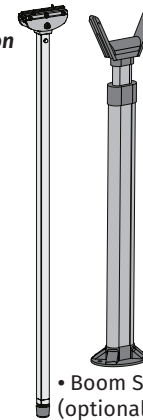

• Boom Supports
(optional)

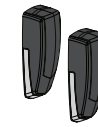

• MF30 photocells



• 2 FALK transmitters



• User manual

• Barrier door key

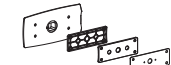

• Boom and mounting accessories

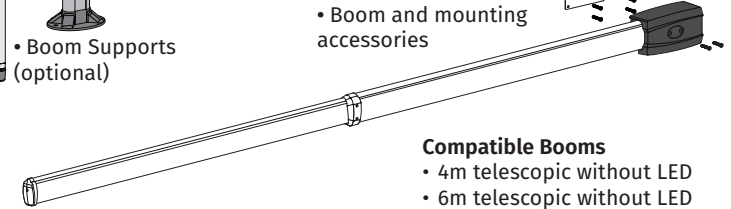

Compatible Booms

- 4m telescopic without LED
- 6m telescopic without LED
- * 4m telescopic with LED
- * 6m telescopic with LED
- * Only in the TURBO version**



Some of these accessories may be sold separately. Consult your distributor.

DIMENSIONS

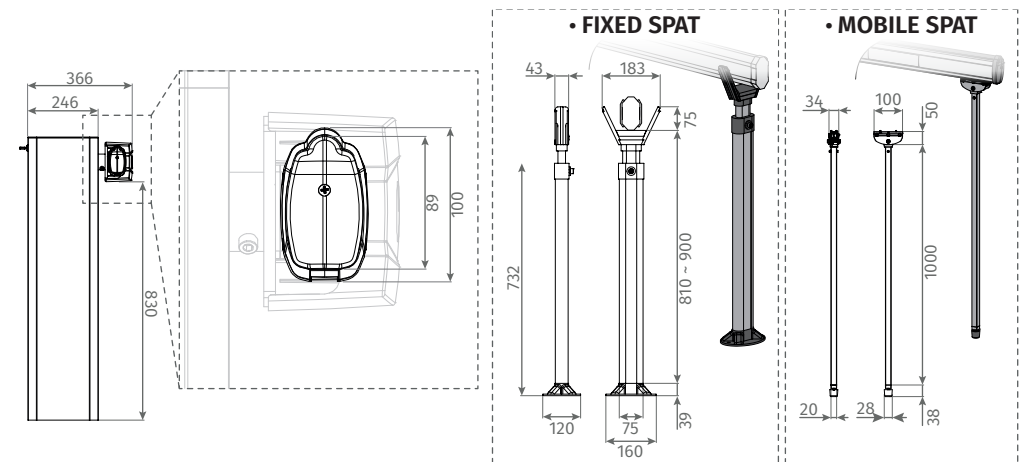

02. AUTOMATISM

DIMENSIONS

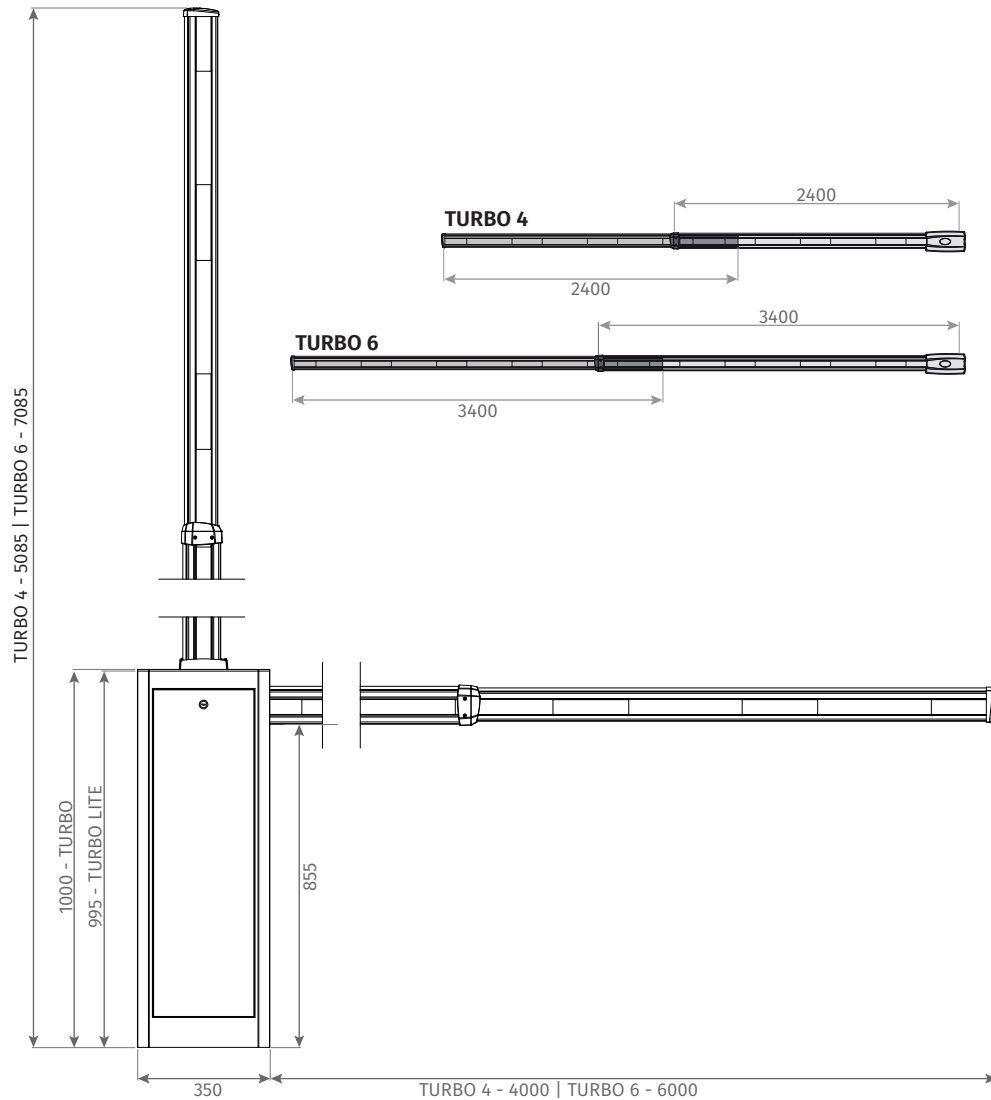

03. INSTALLATION

INSTALLATION AND ADJUSTING PROCESS



To correctly install the barrier, follow the steps below in the order in which they are found.

• INSTALLATION AND MECHANICAL ADJUSTMENT OF THE BARRIER

DESCRIPTION		PAGE
01 •	Build the foundation and fix the structure.	7B
02 •	Remove the protection plate 09 , by unscrewing the two screws.	6
03 •	Check that the closing movement is in the correct direction. If not, reverse the position of the boom.	11A
04 •	Check the number of springs required.	14
05 •	Assemble and adjust the desired boom length.	9 to 10
06 •	Check the need for boom support.	10
07 •	Adjust the leveling of the boom when it is closed.	9
08 •	Adjust spring compensation. Consult the adjusting table.	14
09 •	Install protection plate 09 .	6

• POWER SUPPLY AND CONTROL BOARD PROGRAMMING

DESCRIPTION		PAGE
01 •	Pass the boom cables and connect to the control board 23 .	8
02 •	Check the need to add optional modules or connections.	16 to 17B*
03 •	Connect the power cable.	
04 •	Set boom length P0 → HA .	8A*
05 •	Check parameter P0 → dl .	8A*
06 •	Set parameter for the boom.	8A*
07 •	Perform automatic programming P0 → AU .	7B*
08 •	Activate the safety devices, if used, in P5 and P6 .	9B and 10A*
09 •	Set the automatic closing time P4 → AF .	9A*
10 •	Give an opening order to check operation.	
11 •	If the opening is not smooth, adjust the parameters using the adjusting table.	13A
12 •	Activate the functions relevant to your installation.	



*Consult the MC90BL-BR-TUR control board manual

03. INSTALLATION

INSTALLATION MAP EXAMPLE

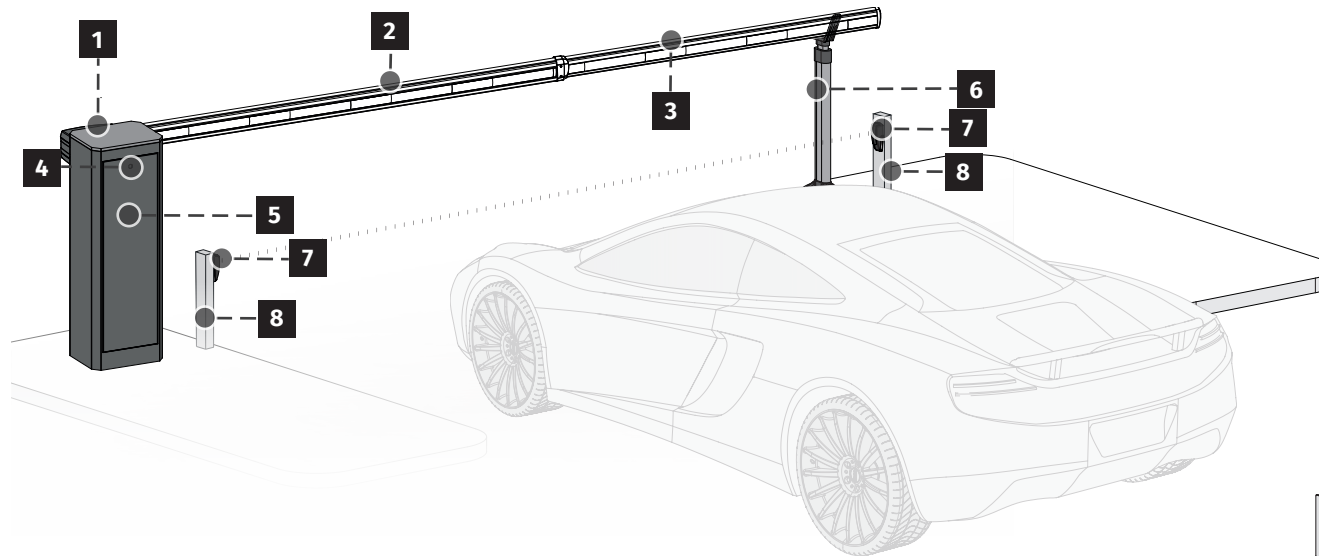

- 1• Barrier box
- 2• Boom
- 3• Boom extension
- 4• Door lock
- 5• Box door
- 6• Spat (optional)
- 7• Photocells
- 8• Photocell bracket
- 9• Protective plate
- 10• Spring nuts
- 11• Springs
- 12• Spring nuts
- 13• Spring support plate
- 14• Crank
- 15• Motor
- 16• Main shaft
- 17• Spring lever
- 18• Connecting rod brake
- 19• Stoppers
- 20• Mechanism arm
- 21• Motor arm
- 22• * LED flashing light
- 23• Control board
- 24• Micro

***NOTE: Only available on the TURBO model.**

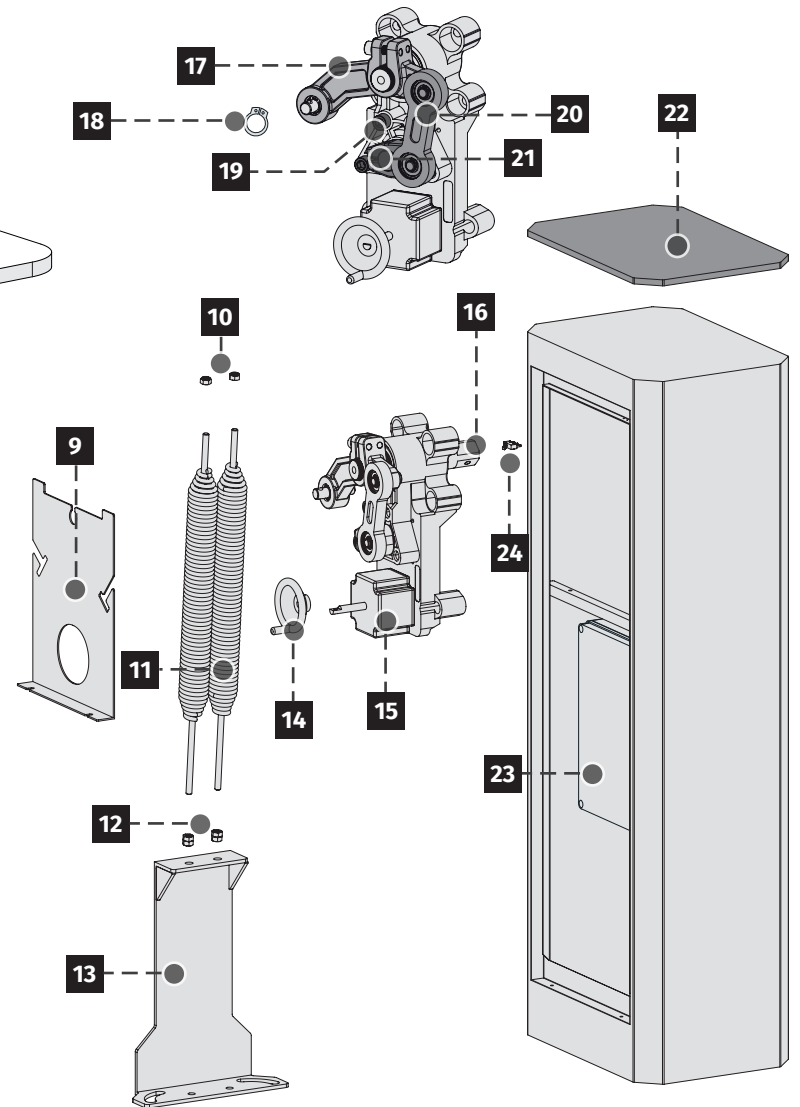

Use rigid and/or flexible tubes, suitable for installing electrical cables. Always separate low voltage cables from 110/230Vac~ cables, to avoid any type of interference. The map shown refers to a standard installation. Consult the kit in the catalogue. If you need other accessories, please contact us.

03. INSTALLATION

DOOR OPENING



Under no circumstances should you place your hands on any component of the barrier when the automation is connected to the power supply.

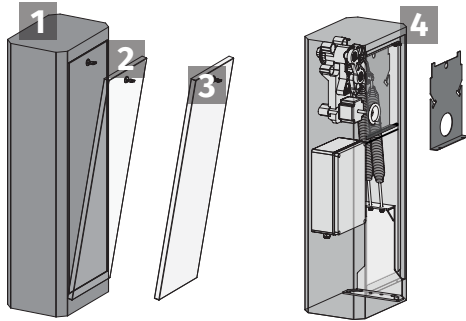

Follow the following steps to access the barrier automation:

- 1 • Insert the door key.
- 2 • Slightly pull the top of the door out.
- 3 • Lift the door to release it from the base of the barrier box.
- 4 • Release the screws on the protection plate to access the mechanism, if necessary.

MANUALLY MOVE THE BOOM

In case of emergency or during the installation/adjustment phase of the barrier, it may be necessary to move the boom manually. To do this, you must access the interior of the automation (see "OPENING THE DOOR"), turn the handle until the boom comes out of the 90° angle (approximately 10 laps) and then you can move the boom by hand.



Whenever the cover is removed, the barrier will stop working due to the emergency circuit.

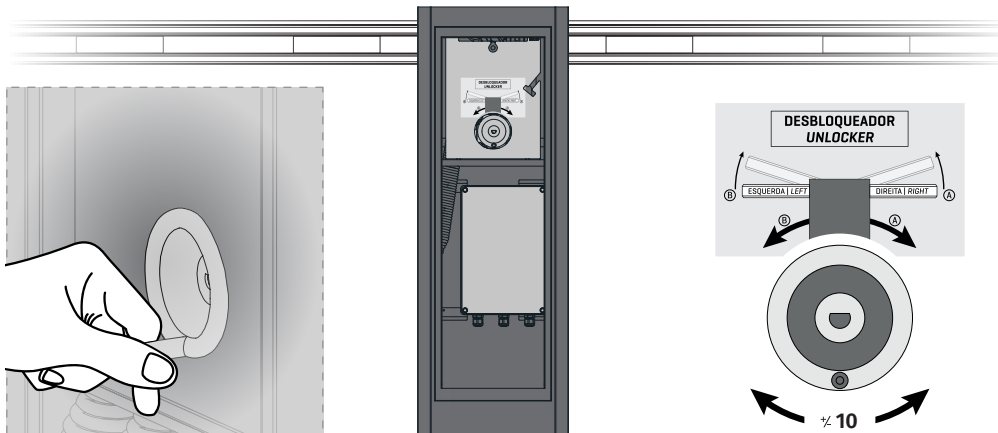

03. INSTALLATION

AUTOMATION INSTALLATION

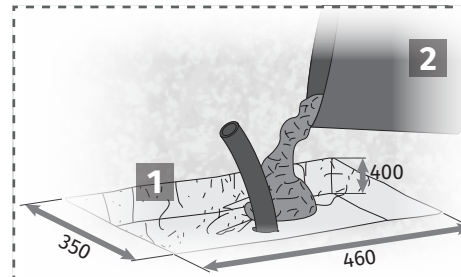

• CREATE FOUNDATION

- 1 Make a hole measuring 350x460mm and 400mm (or greater) deep to create the fixing foundation.
- 2 Fill with concrete and smooth the top so that it is perfectly level.
- 3 While the cement is still fresh, place bolts (Minimum 200mm height) and the nuts in the center of the holes in the base of the barrier box, and then apply the barrier box making it enter 200mm (minimum) into the cement.
- 4 If you want to adjust the barrier box a little, you can slightly release the nuts to rotate it a few degrees.

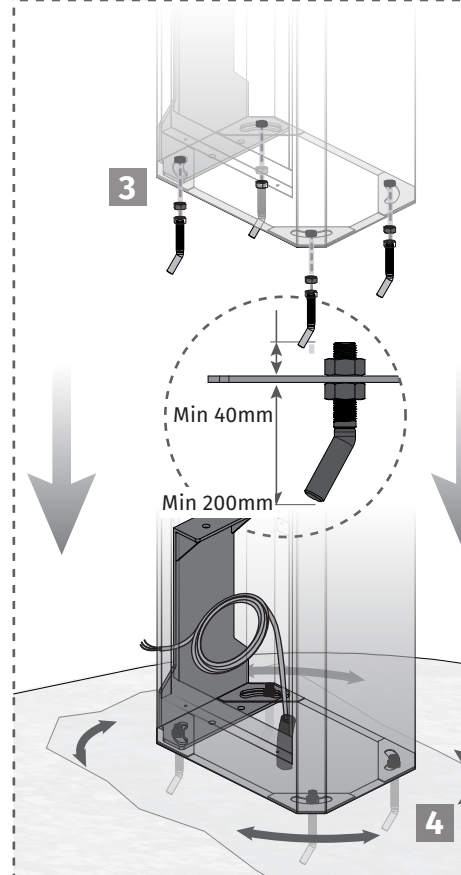

• EXISTING FOUNDATION

- 1 With the barrier in place, mark the holes in the foundation. Drill the foundation at these markings and apply appropriate dowels to fix the barrier.
- 2 Position the barrier on the foundation, leaving it centered with the holes and fix it by applying the screws from the inside of the barrier.

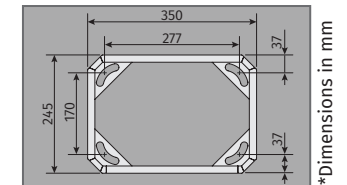

*Dimensions in mm



Leave cables with a length that guarantees easy connection to the control board.

03. INSTALLATION

POWER CABLE

*The barrier structure has guides on the inside through which the barrier wiring must pass in an organized manner to the top of the barrier.

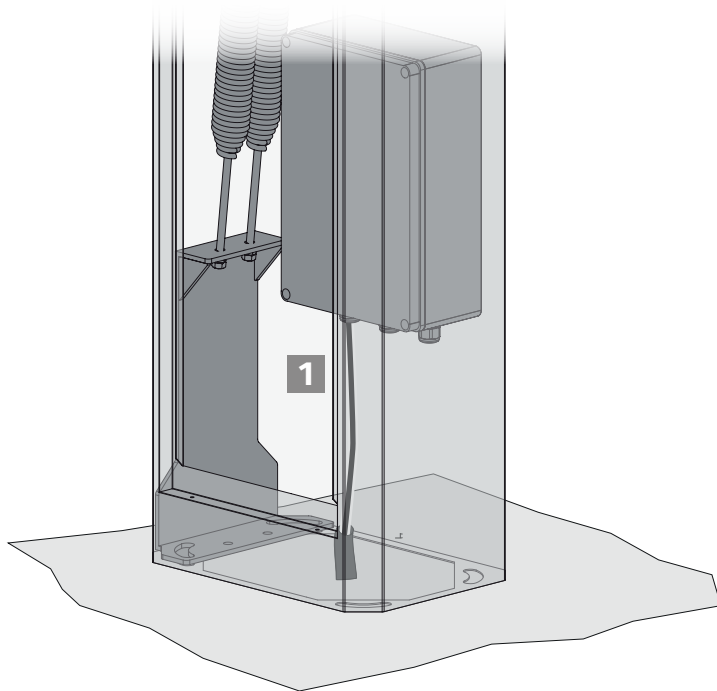

- 1 Guide the power cables that come from the ground through the inside of the barrier box, storing them so that they are protected.
- 2 When the power cable reaches the control board, connect the wires to the connector on the control board box.
Connect the wires in the order shown in the image

* NOTE: Only available in the TURBO version.

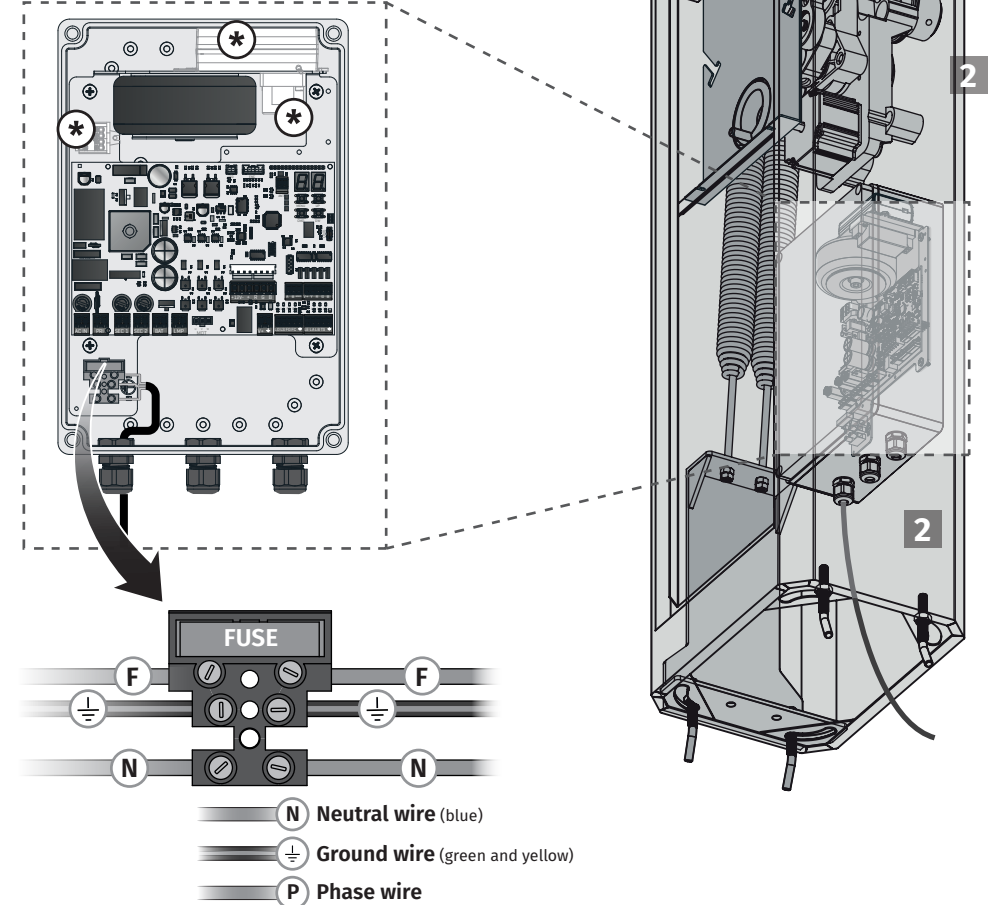

Important: Check the voltage of your transformer before connecting the power supply if it is 230Vac~ or 110Vac~.
See page 14 for more detailed information

03. INSTALLATION

BOOM ASSEMBLY



*If you order the barrier without specifying the position of the boom, it will be mounted on the right. If the barrier is not in the desired position, follow the instructions on the next page to reverse it.

1 • RIGHT BOOM (Standard) *

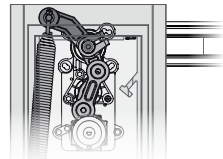

Horizontal boom (spring stretched)

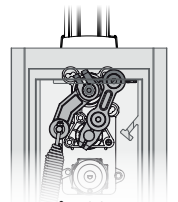

Vertical boom (spring retracted)

2

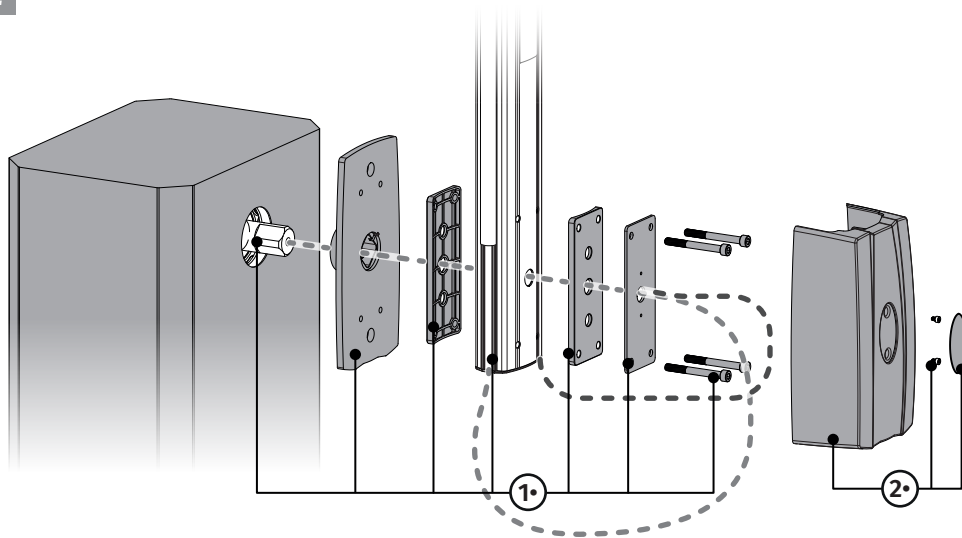

- 1 Check that the position of the boom is horizontal (*see image 1*).
- 2.1 Group and fit the pieces in the indicated order. Attach the parts to the boom fixing plate with screws provided in the packaging.
- 2.2 Pass the safety edge and lighting wires through the hole in the centre of the motor shaft before fitting the boom cover.

Fit the boom cover and secure it with the screws provided in the package.

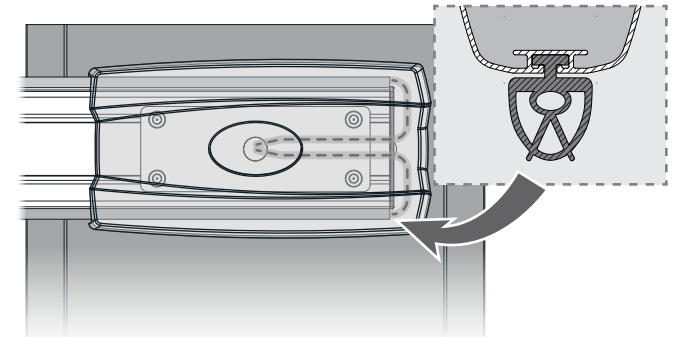

All Motorline barriers have the possibility of installing safety edges and signaling LEDs.

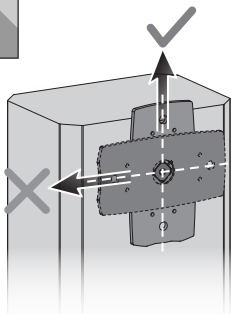

Boom bracket in vertical position

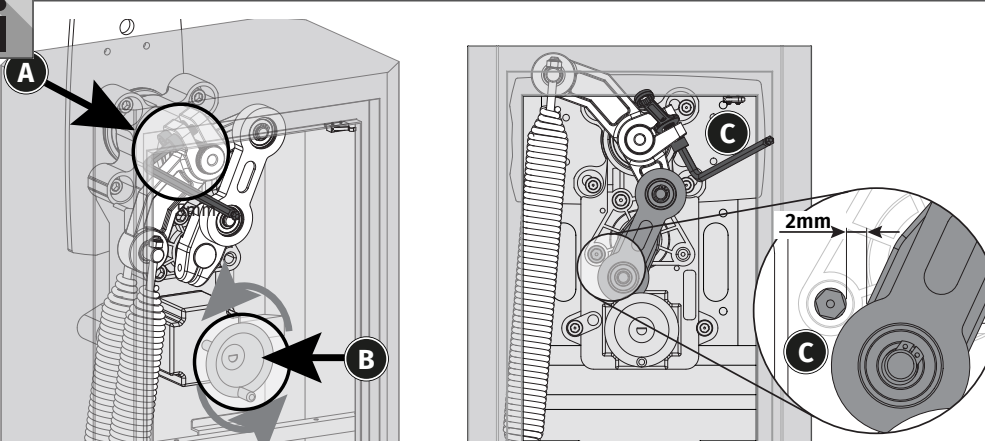

If the boom is not horizontal, you can adjust its level. To do this, you must:

- 1 • Place the motor arm in the open position, remove screws **A**, turn the crank **B** until the boom is in the closed (horizontal) position and with the motor arm about 2mm from stopper **C**. Place them on the opposite side. Tighten the screws slightly in this direction and, using a tool (e.g. an open-end spanner), loosen the spring lever.
- 2 • Then move the boom by hand until it is in the correct position. If using Spat, place the boom against the fixed Spat stopper or the mobile Spat on the floor. In this case, the boom always remains in the same position.
- 3 • Before tightening the screws in their original position, check that the boom is horizontal (you can use a level to confirm this).

03. INSTALLATION

FIX BOOM SUPPORTS (OPTIONAL)

• SET EXTENSIBLE BOOM LENGTH

- 1 Start by establishing the length of the boom so you can then place the support, as seen in the image below.

The boom must exceed the position of the support arm by 50mm.

- 2 After placing the boom with the desired dimension, fix it with the two self-tapping screws on the fixed part of the boom.

• FIXED BOOM SUPPORT APPLICATION

Once the length of the boom is established, determine where to attach the boom support to the ground.

- 3 Drill two holes at the installation location to fix the support and fix it.

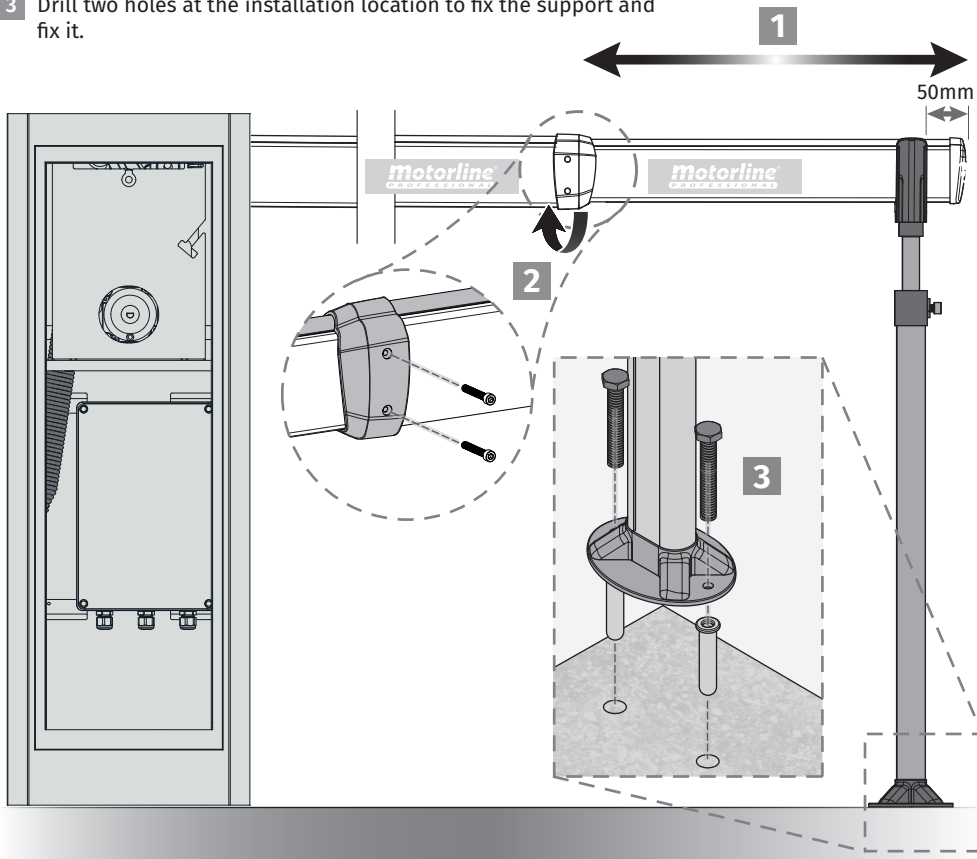

• ADJUST THE HEIGHT OF THE SUPPORT (FIXED)

If the height of the support arm is not adjusted to the height of the boom, you will need to adjust the height of the arm. To do this, follow the following steps:

- 4 Loosen the support arm locking pin with an Umbrako wrench.
- 5 Raise or lower the support arm to place the support at the height needed to support the boom.
- 6 Tighten the support arm lock pin to lock the support in the set position.

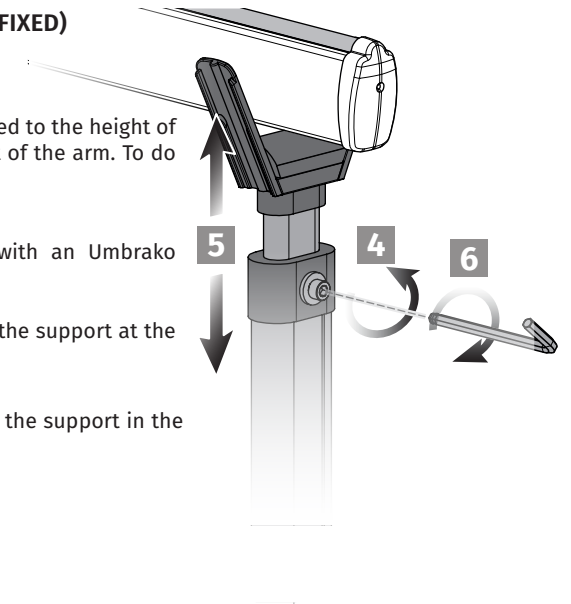

• MOBILE BOOM SUPPORT APPLICATION

- 7 Fix the mobile support to the boom by tightening the two screws at the top of the support.
- 8 Detach the base from the mobile support. It may be necessary to remove side screws.
- 9 Tighten or loosen the adjustment screw located at the top of the floor stopper.
- 10 Put everything back together and test if it is as expected. Repeat if necessary.

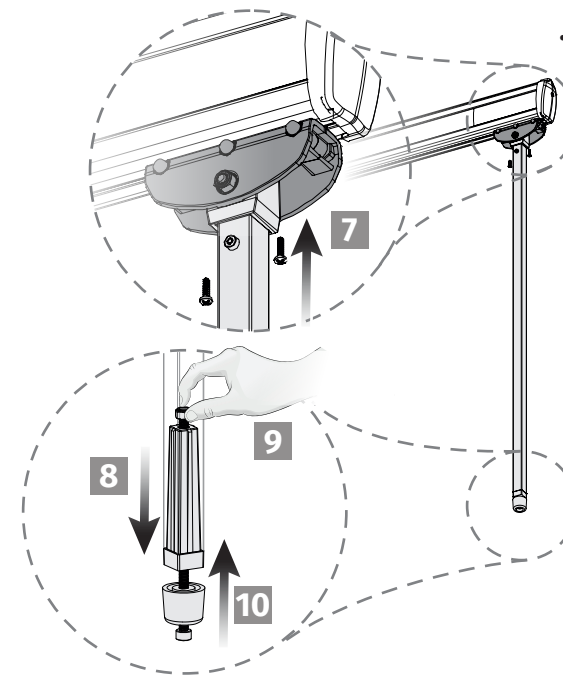

03. INSTALLATION

REVERSE BARRIER POSITION SX → DX

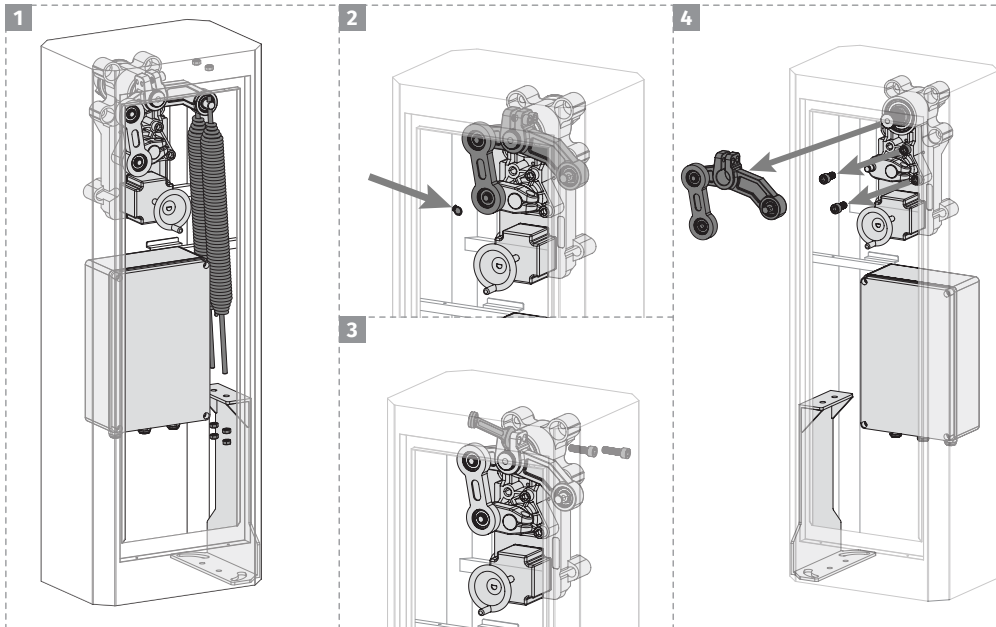

- 1 Release the M8 nuts at the ends of the springs.
- 2 Remove the brake that secures the motor arm.
- 3 Remove the screws from the lever fastener and loosen the fastener with the aid of a tool.
- 4 Remove the arm and lever assembly from the motor shaft.

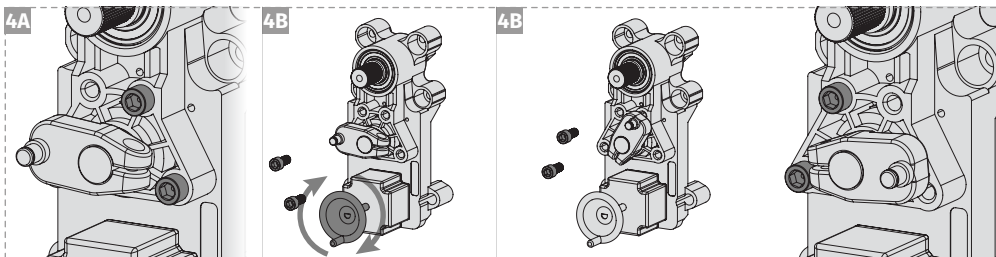

- 4A Remove the two stoppers.
- 4B Then turn the crank to rotate the position of the motor arm.
- 4C Place the two stoppers on the opposite side.

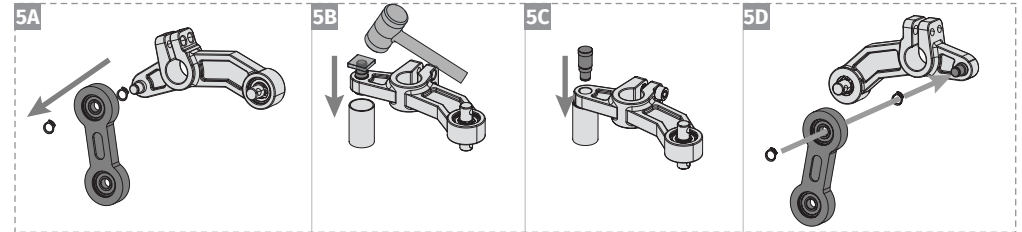

- 5A Remove the brake that secures the motor arm to the lever.
- 5B Remove the pin on the fixing lever with a press or hammer.
- 5C Place it in the opposite direction.
- 5C Reattach the brake and motor arm in the same initial position.

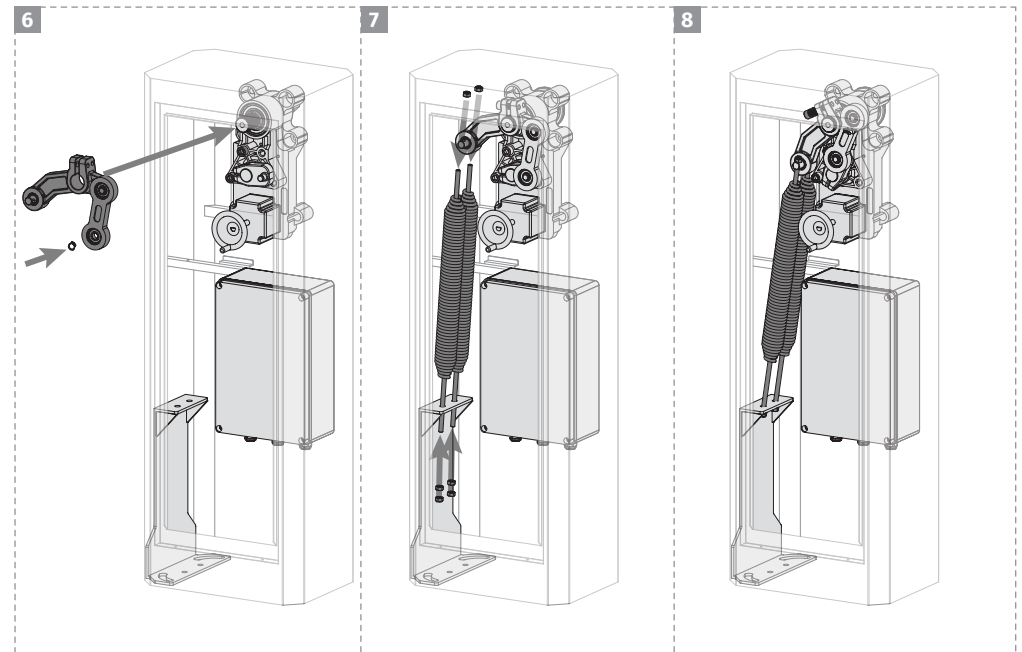

- 6 Replace the motor arm and lever assembly on the motor shaft.
- 7 Place the springs and secure them with the M8 nuts on the spring support plate and motor arm.
- 8 Adjust the springs. Refer to the tuning table.

03. INSTALLATION

ADJUST THE SPRING

i Before adjusting the spring, manually place the boom in a vertical position so that the springs are in the position of least tension, and move the connecting rod approximately **5mm** away from the stopper.

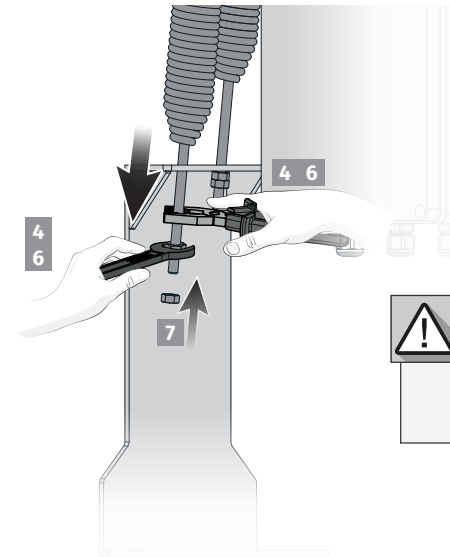
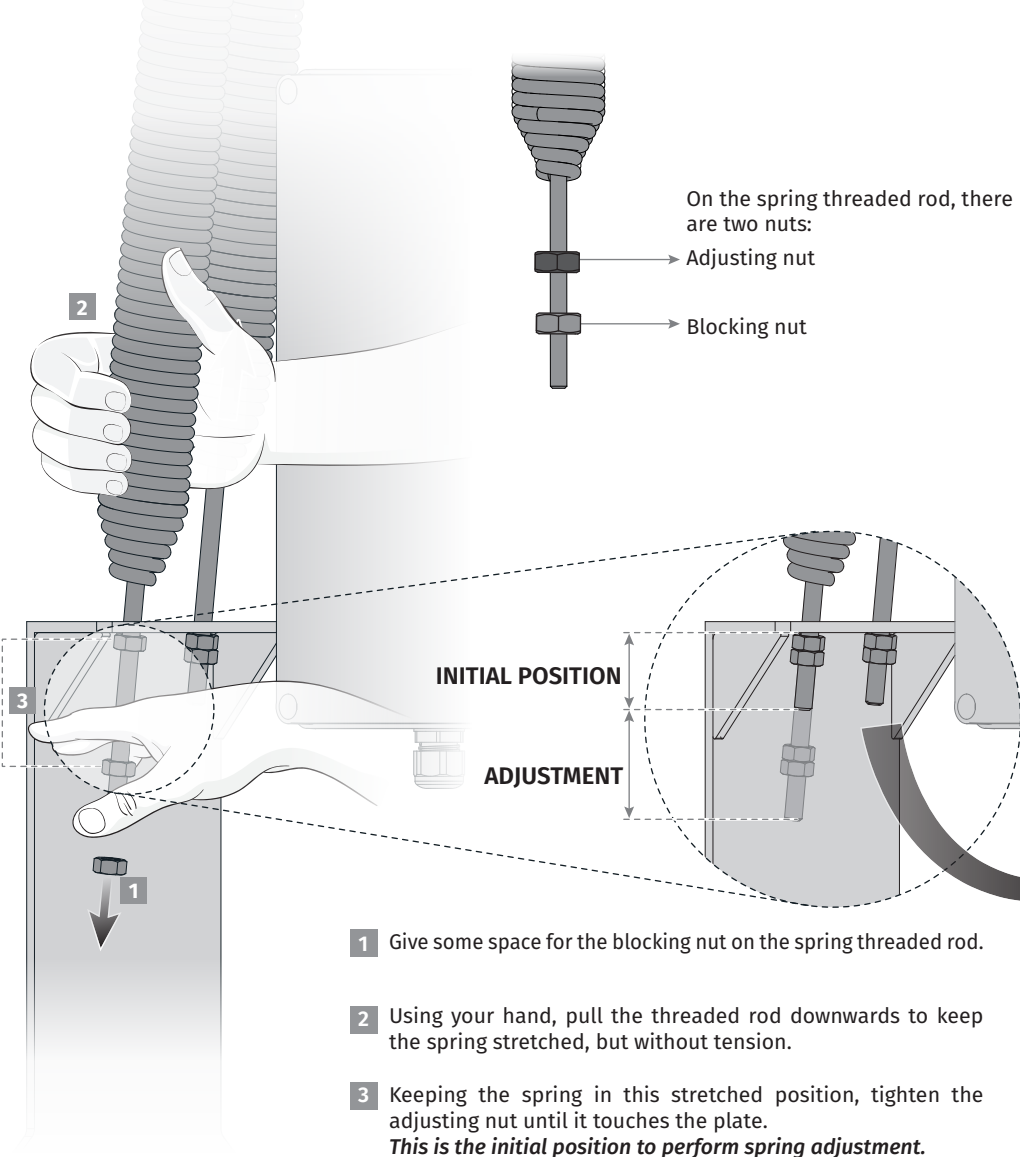

! **Attention:** This operation must be carried out with the control board disconnected from the power supply as it causes additional friction to the movement of the motor.

6 If the boom does not remain balanced, tighten or loosen the adjusting nut to achieve the best possible balance.

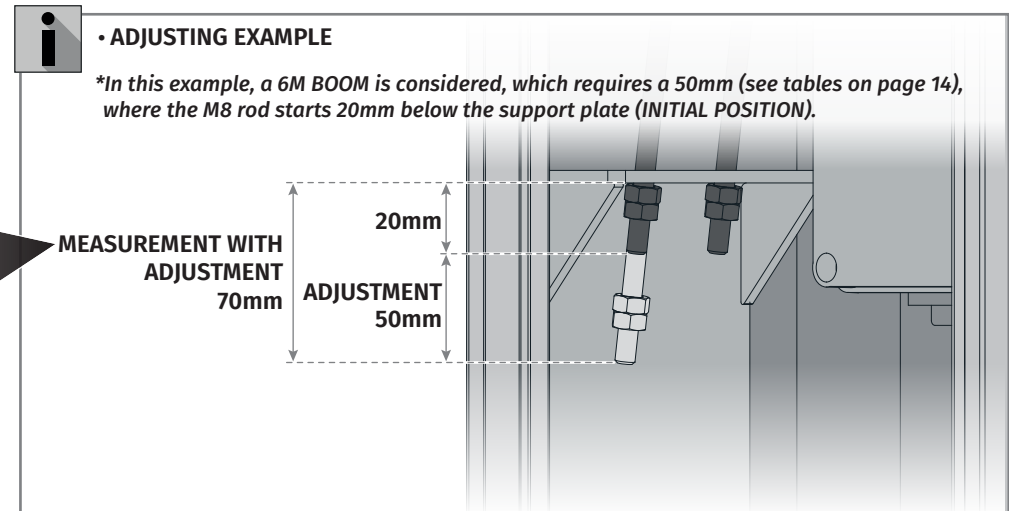

03. INSTALLATION

TEST SPRING ADJUSTMENT



You must turn the motor crank until it stops the counter-cycle and you can move the boom by hand.

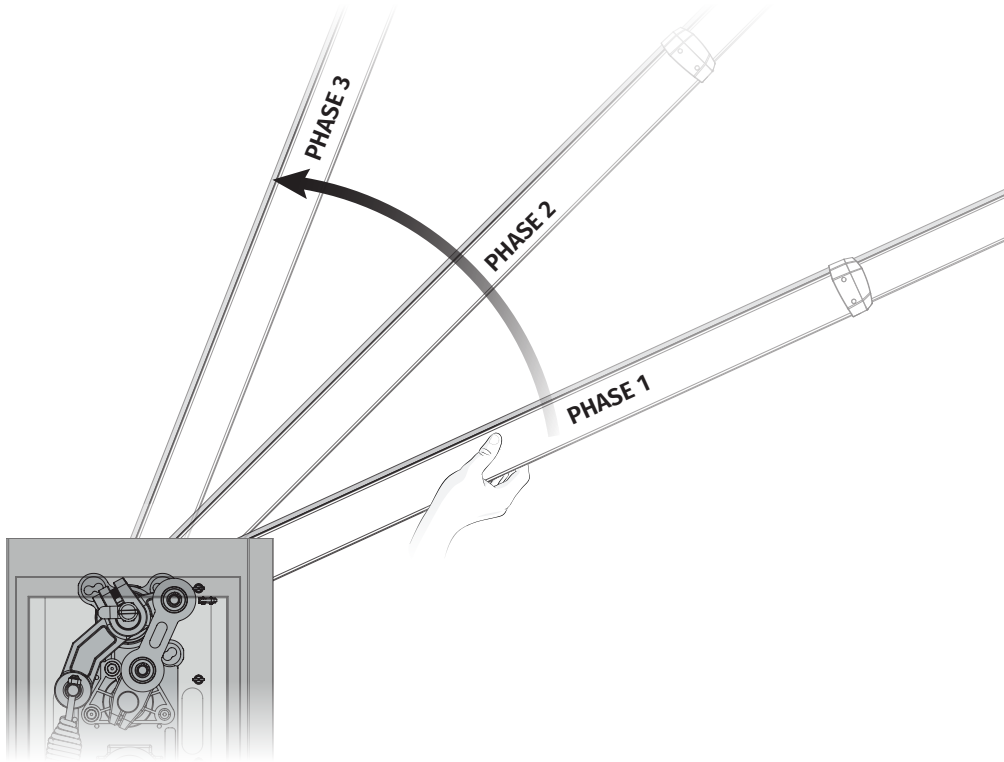

- 1 Manually place the boom in the **phase 1** position. When you release the boom, it should remain stable, or rising very slightly.
- 2 Place the boom in **phase 2**, and **phase 3** and repeat the test from step 1 in each of the different phases.
With the tuning you should be able to reach a state in which, moving the boom by hand, it should remain stable in any position in which you release it.

- If the boom goes down when you release it, tighten the spring slightly and test again.
- If the boom rises when you release it, loosen the spring slightly and test again.

03. INSTALLATION

TUNING TABLE

Boom Length	2500	3000	3500	4000	4500	5000	5500	6000
Opening time (seconds)	1,5	2,5	3	3	3,5	4	4,5	5
Parameter P2-SO	9	8	6	6	5	4	3	2
Parameter P2-SC	2	2	1	1	1	1	1	1



The values mentioned in the table above must be used for the speed parameter P2-SO and P2-SC, as well as in the table below for spring tuning. If the values are not applied, you may lose your warranty.

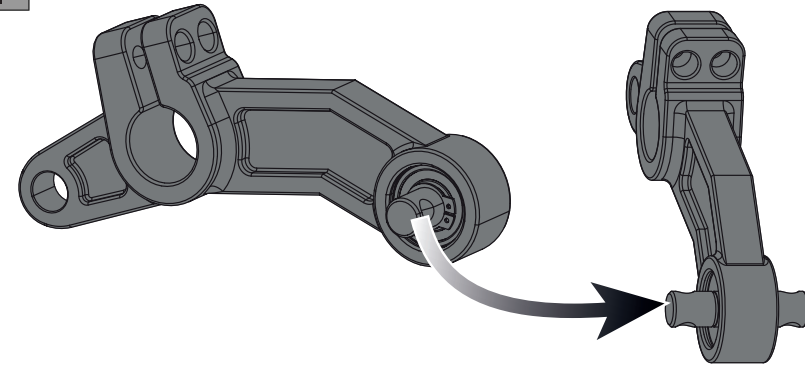

- Depending on the condition of the spring, there may be a tolerance of 5mm in relation to the values indicated in the table.
- You should test the minimum adjustment necessary to compensate the weight of the boom.
- **The values mentioned in the table must be used. If the values are not applied, the guarantee may be cancelled.**

03. INSTALLATION

TUNING TABLE



The values in the table refer to booms WITHOUT LEDs - TURBO-LITE.

Note: Measurements refer to clear passageway.

SIMPLE BOOM	TURBO-LITE 4			TURBO-LITE 6			
Boom Length	3000	3500	4000	4500	5000	5500	6000
Quantity of springs	1 un.			1 un.	2 un.		
Spring adjustment (mm)	1mm	5mm	15mm	70mm	1mm	5mm	15mm
BOOM WITH RUBBER	TURBO-LITE 4			TURBO-LITE 6			
Boom Length	3000	3500	4000	4500	5000	5500	6000
Quantity of springs	1 un.			2 un.			
Spring adjustment (mm)	5mm	20mm	25mm	70mm	11mm	17mm	30mm
BOOM WITH SPAT	TURBO-LITE 4			TURBO-LITE 6			
Boom Length	3000	3500	4000	4500	5000	5500	6000
Quantity of springs	1 un.			2 un.			
Spring adjustment (mm)	1mm	10mm	25mm	1mm	5mm	15mm	25mm
BOOM WITH RUBBER AND SPAT	TURBO-LITE 4			TURBO-LITE 6			
Boom Length	3000	3500	4000	4500	5000	5500	6000
Quantity of springs	1 un.			2 un.			
Spring adjustment (mm)	5mm	25mm	45mm	1mm	15mm	27mm	40mm



The values in the table refer to booms WITH LEDs - TURBO.

Note: Measurements refer to clear passageway.

SIMPLE BOOM	TURBO 4			TURBO 6			
Boom Length	3000	3500	4000	4500	5000	5500	6000
Quantity of springs	1 un.			2 un.			
Spring adjustment (mm)	5mm	20mm	35mm	1mm	10mm	25mm	40mm
BOOM WITH RUBBER	TURBO 4			TURBO 6			
Boom Length	3000	3500	4000	4500	5000	5500	6000
Quantity of springs	1 un.			2 un.			
Spring adjustment (mm)	15mm	30mm	45mm	11mm	25mm	40mm	60mm
BOOM WITH SPAT	TURBO 4			TURBO 6			
Boom Length	3000	3500	4000	4500	5000	5500	6000
Quantity of springs	1 un.			2 un.			
Spring adjustment (mm)	10mm	30mm	50mm	5mm	15mm	25mm	40mm
BOOM WITH RUBBER AND SPAT	TURBO 4			TURBO 6			
Boom Length	3000	3500	4000	4500	5000	5500	6000
Quantity of springs	1 un.			2 un.			
Spring adjustment (mm)	20mm	40mm	60mm	15mm	30mm	45mm	60mm

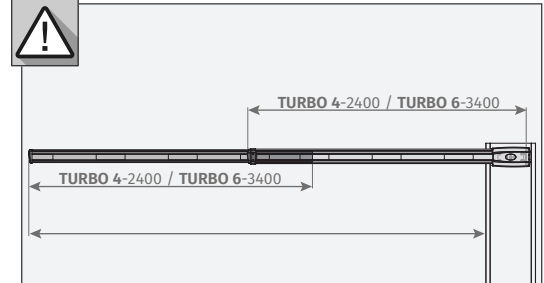

NOTE: If you want to adjust a TURBO-6 boom (3400+3400) for measurements up to 4000, you must cut the profiles to the measurements of a TURBO-4 boom (2400+2400). Only then will you be able to maintain the values in the table.

04. CONNECTIONS

CONNECTION DIAGRAM TURBO LITE - MC90BL-BR-TUR

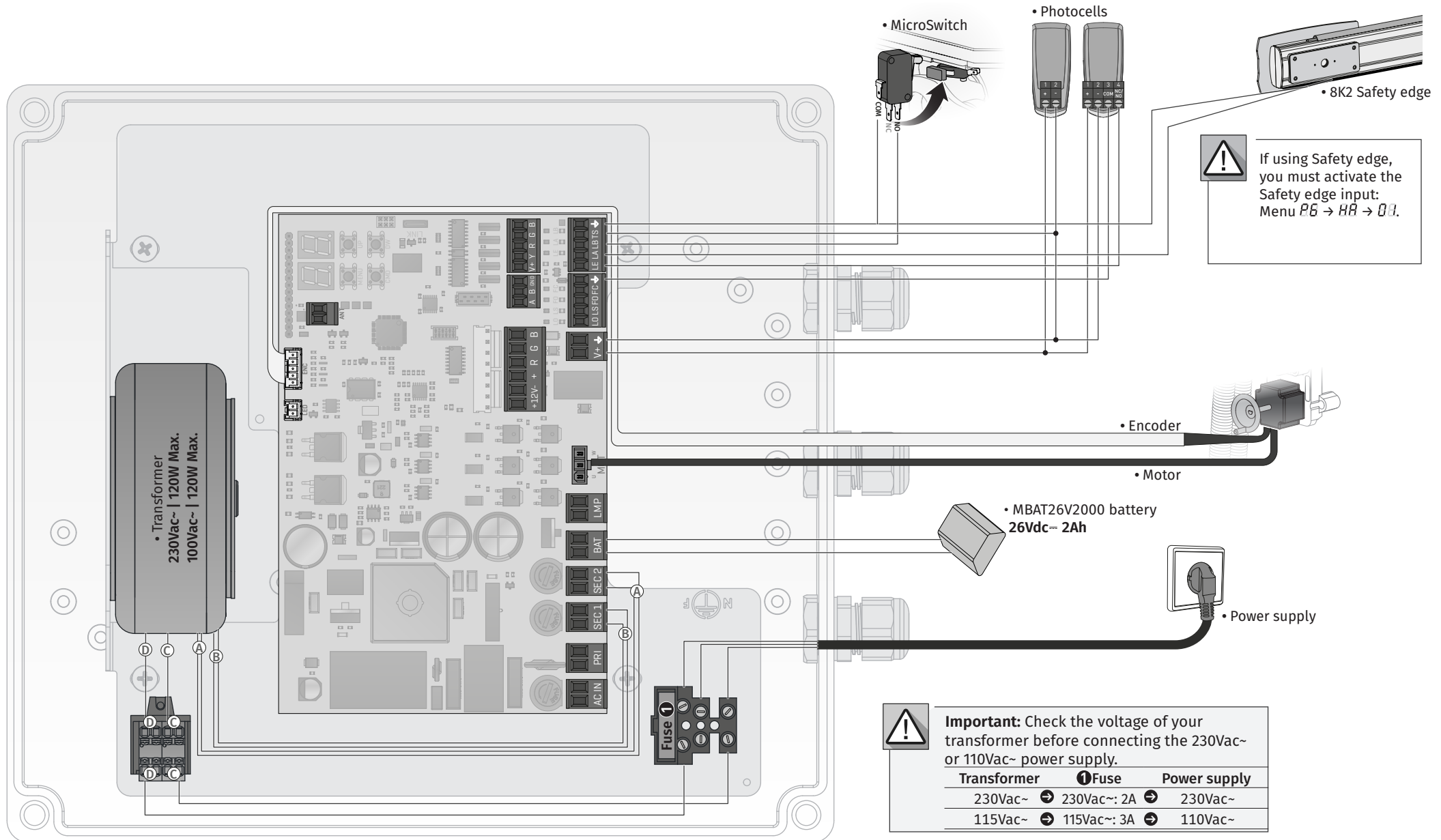

04. CONNECTIONS

CONNECTION DIAGRAM TURBO - MC90BL-BR-TUR

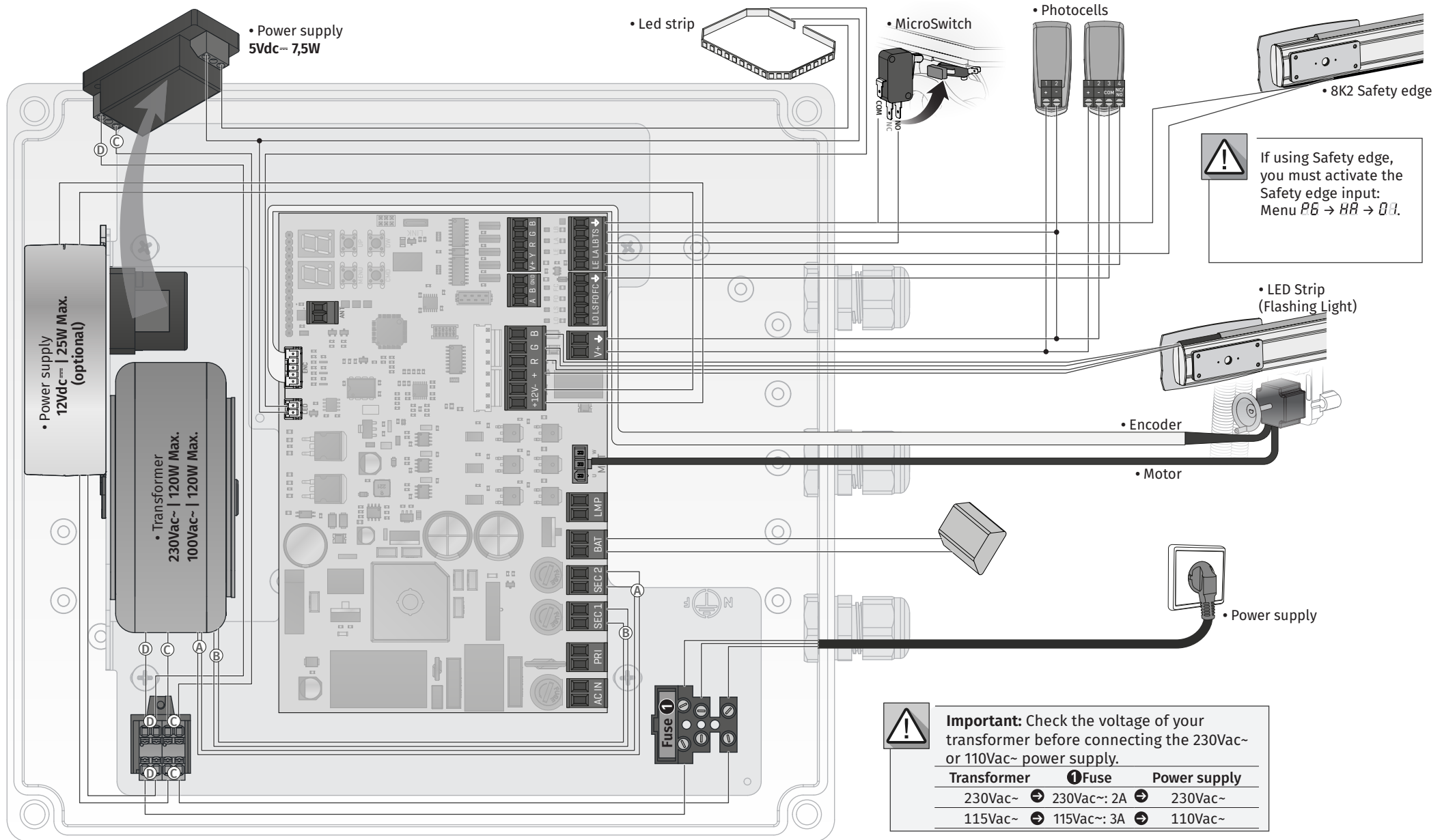

04. CONNECTIONS

CONNECTION DIAGRAM - MM90-RGB MODULE (OPTIONAL)

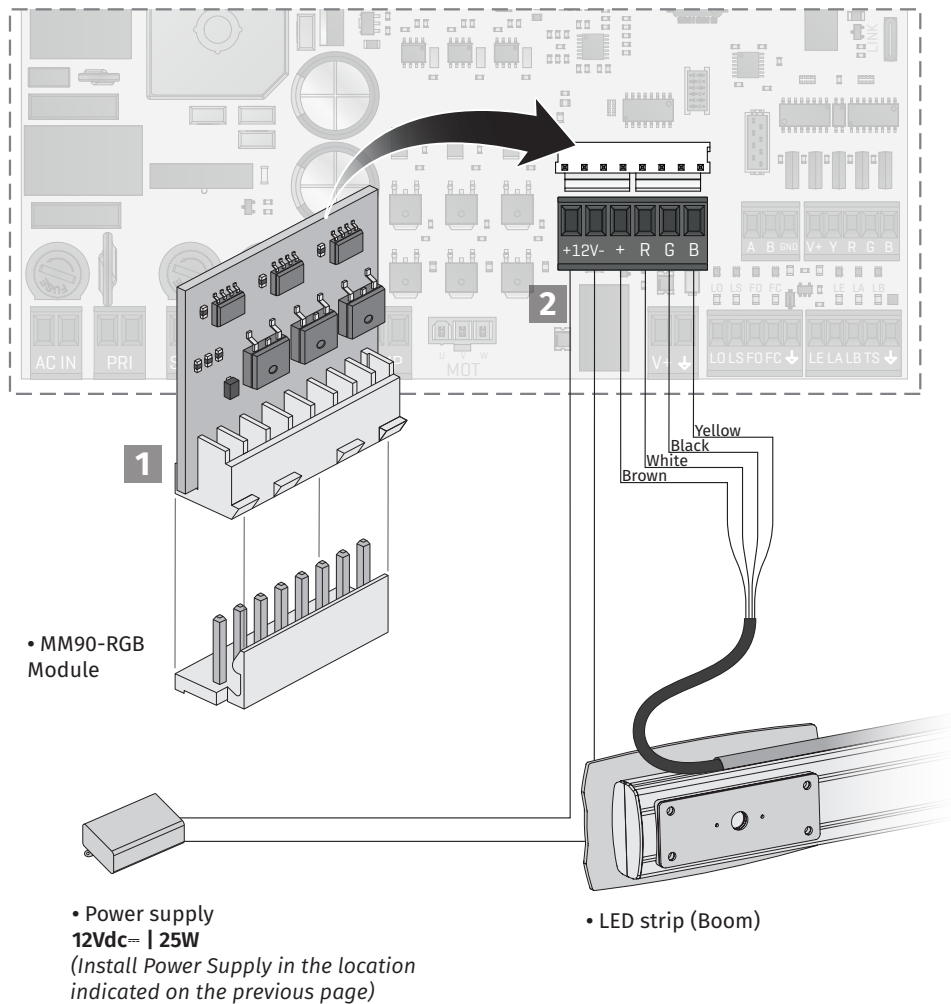

- 1 Fit the MM90-RGB module onto the control board;
- 2 Connect the LED Strip cables according to the diagram;
- 3 To configure the RGB module operating mode, see parameter $E9 \rightarrow HR$.

04. CONNECTIONS

CONNECTION DIAGRAM - MASTER / SLAVE (OPTIONAL)

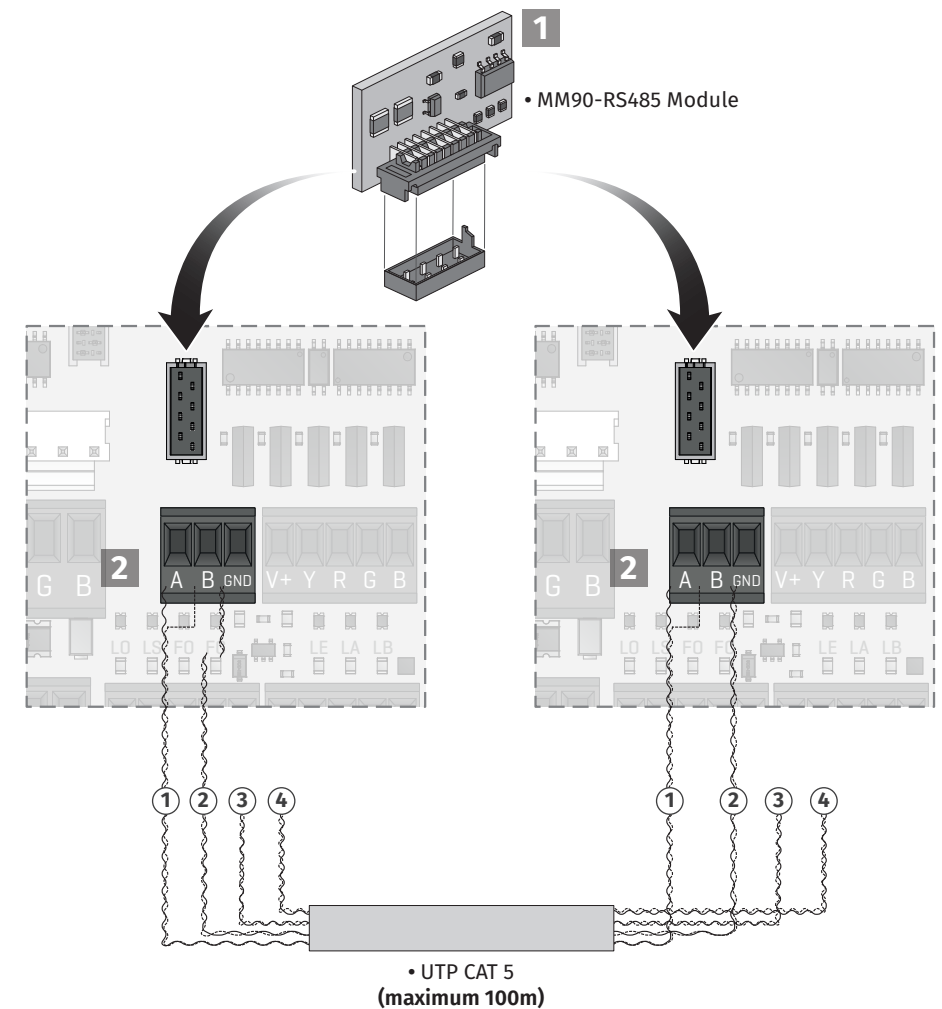

- 1 Fit the MM90-RS485 module onto the MASTER board and the SLAVE board;
- 2 Connect the two boards with a UTP CAT 5 cable;
- 3 Sets the $PD \rightarrow n5$ parameter to 00 on the MASTER board, and 03 on the SLAVE board.

05. TROUBLESHOOTING

INSTRUCTIONS FOR END CONSUMERS / SPECIALIZED TECHNICIANS

Anomaly	Procedure	Behavior	Procedure II	Discovering the origin of the problem
• Barrier does not work	• Check that the 230Vac~ power supply is connected to the automation and that the fuse is working correctly.	• Still not working	• Consult a specialized technician.	<ol style="list-style-type: none"> Open the barrier door; Measure the 24Vdc= output of the transformer to detect the location of the fault; <p>A) It has 24Vdc=:</p> <ol style="list-style-type: none"> Check whether the control board is supplying power to the barrier to detect whether the fault is in the motor or the control board. Replace the damaged component or send it to service for diagnosis and repair. <p>B) It does not have 24Vdc=:</p> <ol style="list-style-type: none"> Check the 230Vac~ input of the transformer. If it has 230Vac~ the problem is with the transformer. If not, the problem will be with the fuse, electrical cables or the electric current itself. Check all systems.
	• Check STOP.	• Still not working	• Consult a barrier technician.	<ol style="list-style-type: none"> Check that the barrier door limit switch is activated when it is closed; Check that the LB input LED turns on when the limit switch is pressed; Check the entire photocell connection circuit to the control board.
• Barrier does not move but makes noise	• Unlock the barrier and move manually to check for mechanical problems.	• Is the barrier stuck?	• Consult a barrier technician.	<ol style="list-style-type: none"> Check all axes and movement systems associated with the barrier to find out what the problem is. Also check that the spring is in good condition and can support the boom.
		• Does the boom move easily?	• Consult a specialized technician.	<ol style="list-style-type: none"> If the motor works, the problem is with the control board. Remove it and send it to technical services for diagnosis; If the motor does not work, remove the motor and send it to technical services for diagnosis.
• Barrier opens but does not close	<ol style="list-style-type: none"> Check if there is any obstacle in front of the photocells; Check that the photocells are working. Pass your hand over the front and check if the relay makes any noise. Check whether any of the barrier control devices are stuck and sending a permanent signal; Check the Safety edge connections. 	• The barrier opened but did not close.	• Consult a specialized technician.	<ol style="list-style-type: none"> Check that the display is ON to confirm the existence of power; Check that the photocells are powered at the control board output; Access the menu on the display and deactivate the photocells and STOP; Try to close; <p>A) Closed:</p> <ol style="list-style-type: none"> The problem is in one of these two systems. Activate the photocells and check that the barrier closes. If it closes, the problem will be the STOP. Activate it in the menu and try closing the barrier to be sure. <p>B) Did not close:</p> <ol style="list-style-type: none"> The problem is with the motor or control board. If there is no power, the problem is with the control board.
• Barrier does not make a complete route	• Unlock the barrier and move manually to check for mechanical problems.	• Found problems?	• Consult a barrier technician.	<ol style="list-style-type: none"> Check all axes and motion systems associated with the barrier to find out what the problem is. Also check that the spring is in good condition and can support the boom.
		• Does the barrier move easily?	<ol style="list-style-type: none"> Reprogram the barrier course; Consult a specialized technician. 	<ol style="list-style-type: none"> Check that the compensations of the barrier springs are well made; Change the sensitivity in menu P2 until the barrier moves without reversing direction; This adjustment must be made so that the barrier reverses when it encounters an obstacle; Change the force in menu P2 until the barrier moves without reversing direction;

06. MAINTENANCE

MAINTENANCE TASKS AND FREQUENCY

During maintenance/revision check the parameters mentioned below.
 On the date you carry out the maintenance, mark with an "X" the tasks performed.
Maintenance must be carried out by a specialized technician as regularly as indicated.

	Frequency (months)				Date	Date	Date	Date	Date	Date	Date
	6	12	24	36							
1. OPERATION					/ /	/ /	/ /	/ /	/ /	/ /	/ /
Tightening the support to the ground		X									
Spring calibration (manual test)		X									
Adjusting the spring tension so that when it is closed/open and in the middle, it remains in that position without changing		X									
All axes of movement		X									
Motor noise		X									
Manual unlocking system		X									
General adjustments (electrical and control board force)		X									
Checking the packaging of all cables inside the barrier		X									
Ground wire power protection		X									
Advertising		X									
Label for recording the intervention		X									
CE marking label		X									
Company / Technician:											



Since maintenance standards vary depending on the legislation in force in the country where the barrier is being installed, the installer must verify that the recommended maintenance frequency is correct.