

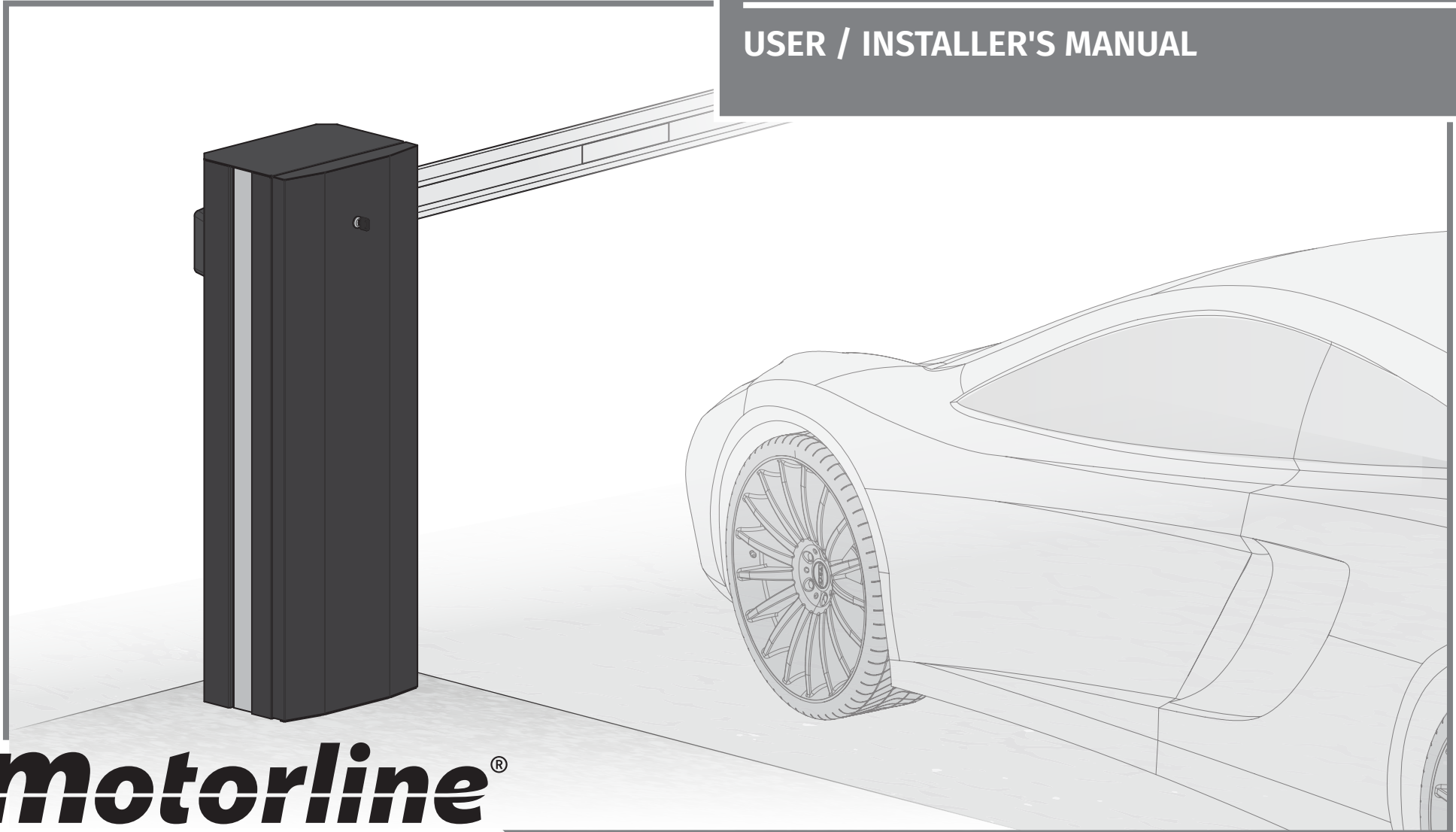

ZUMA

USER / INSTALLER'S MANUAL



00. CONTENT

INDEX

01. SAFETY INSTRUCTIONS	1B
02. AUTOMATISM	
TECHNICAL CHARACTERISTICS	4A
INSTALLATION COMPONENTS	4A
DIMENSIONS	4B
REMOVE THE DOOR	8A
MANUAL OPENING / CLOSING	8B
03. INSTALLATION	
INSTALLATION MAP	9A
FOUNDATION	9B
AUTOMATISM INSTALLATION	10
SPRING POSITION	11A
QUANTITY OF SPRINGS	11B
INSTALLATION OF SPRINGS (ZUMA 4 / ZUMA 6)	12
BOOM ASSEMBLY (ZUMA 4 / ZUMA 6)	13
INSTALLATION OF SPRINGS (ZUMA 8)	14A
BOOM ASSEMBLY (ZUMA 8)	14B
BOOM MOUNTING - S5 AND S6	15A
BOOM MOUNTING - A5 AND A6	15B
FIXING BOOM SUPPORTS	16
ADJUSTMENT OF THE BOOMS	17
ADJUST THE SPRINGS	18
ADJUSTMENT TABLES	19
TEST SPRING ADJUSTMENT	20A
POWER SUPPLY CABLE	20B
STOPPERS ADJUSTMENT	21A
LIMIT SWITCHES ADJUSTMENT	21B
04. CONNECTIONS	
CONNECTION SCHEME	22
05. TROUBLESHOOTING	
INSTRUCTIONS FOR FINAL CONSUMERS / SPECIALIZED TECHNICIANS	25

Simplified EU Declaration of Conformity

The undersigned **MOTORLINE ELECTROCELOS, S.A.**, with registered office at **Travessa do Sobreiro, n.º 29, 4755-474 Rio Côvo (Santa Eugénia), Barcelos**, declares that the present type of radio equipment - **Electromechanical barrier ZUMA** - complies with the Directive 2014/53/EU.





The full text of the applicable declaration of conformity is available at the following Internet addresses:

<https://motorline.pt/certification/zuma>

<https://motorline.pt/certification/sigmax-zuma>



01. SAFETY INSTRUCTIONS

CE	This product is certified in accordance with European Community (EC) safety standards.
RoHS	This product complies with Directive 2011/65/EU of the European Parliament and of the Council, of 8 June 2011, on the restriction of the use of certain hazardous substances in electrical and electronic equipment and with Delegated Directive (EU) 2015/863 from Commission.
	(Applicable in countries with recycling systems). This marking on the product or literature indicates that the product and electronic accessories (eg. Charger, USB cable, electronic material, controls, etc.) should not be disposed of as other household waste at the end of its useful life. To avoid possible harm to the environment or human health resulting from the uncontrolled disposal of waste, separate these items from other types of waste and recycle them responsibly to promote the sustainable reuse of material resources. Home users should contact the dealer where they purchased this product or the National Environment Agency for details on where and how they can take these items for environmentally safe recycling. Business users should contact their vendor and check the terms and conditions of the purchase agreement. This product and its electronic accessories should not be mixed with other commercial waste.
	This marking indicates that batteries should not be discarded like other household waste at the end of their useful life. Batteries must be delivered to selective collection points for recycling.
	The different types of packaging (cardboard, plastic, etc.) must be subject to selective collection for recycling. Separate packaging and recycle it responsibly.
	This marking indicates that the product and electronic accessories (eg. charger, USB cable, electronic material, controls, etc.) are susceptible to electric shock by direct or indirect contact with electricity. Be cautious when handling the product and observe all safety procedures in this manual.

01. SAFETY INSTRUCTIONS

GENERAL WARNINGS

- This manual contains very important safety and usage information. Read all instructions carefully before beginning the installation/usage procedures and keep this manual in a safe place that it can be consulted whenever necessary.
- This product is intended for use only as described in this manual. Any other enforcement or operation that is not mentioned is expressly prohibited, as it may damage the product and put people at risk causing serious injuries.
- This manual is intended firstly for specialized technicians, and does not invalidate the user's responsibility to read the "User Norms" section in order to ensure the correct functioning of the product.
- The installation and repair of this product may be done by qualified and specialized technicians, to assure every procedure are carried out in accordance with applicable rules and norms. Nonprofessional and inexperienced users are expressly prohibited of taking any action, unless explicitly requested by specialized technicians to do so.
- Installations must be frequently inspected for unbalance and the wear signals of the cables, springs, hinges, wheels, supports and other mechanical assembly parts.
- Do not use the product if it is necessary repair or adjustment is required.
- When performing maintenance, cleaning and replacement of parts, the product must be disconnected from power supply. Also including any operation that requires opening the product cover.
- The use, cleaning and maintenance of this product may be carried out by any persons aged eight years old and over and persons whose physical, sensorial or mental capacities are lower, or by persons without any knowledge of the product, provided that these are supervision and instructions given by persons with experienced in terms of usage of the product in a safe manner and who understands the risks and dangers involved.

- Children shouldn't play with the product or opening devices to avoid the motorized door or gate from being triggered involuntarily.
- If the power cable is damaged, it must be replaced by the manufacturer, after-sales service or similarly qualified personnel to avoid danger.
- The device must be disconnected from the electrical network when removing the battery.
- Ensure that blocking is avoided between the actuated part and its fixed parts due to the opening movement of the actuated part.

WARNINGS FOR TECHNICIANS

- Before beginning the installation procedures, make sure that you have all the devices and materials necessary to complete the installation of the product.
- You should note your Protection Index (IP) and operating temperature to ensure that is suitable for the installation site.
- Provide the manual of the product to the user and let them know how to handle it in an emergency.
- If the automatism is installed on a gate with a pedestrian door, a door locking mechanism must be installed while the gate is in motion.
- Do not install the product "upside down" or supported by elements do not support its weight. If necessary, add brackets at strategic points to ensure the safety of the automatism.
- Do not install the product in explosive site.
- Safety devices must protect the possible crushing, cutting, transport and danger areas of the motorized door or gate.
- Verify that the elements to be automated (gates, door, windows, blinds, etc.) are in perfect function, aligned and level. Also verify if the necessary mechanical stops are in the appropriate places.
- The control board must be installed on a safe place of any fluid (rain, moisture, etc.), dust and pests.
- You must route the various electrical cables through protective tubes, to protect them against mechanical exertions, essentially on

01. SAFETY INSTRUCTIONS

the power supply cable. Please note that all the cables must enter the control board from the bottom.

- If the automatism is to be installed at a height of more than 2,5m from the ground or other level of access, the minimum safety and health requirements for the use of work equipment workers at the work of Directive 2009/104/CE of European Parliament and of the Council of 16 September 2009.
- Attach the permanent label for the manual release as close as possible to the release mechanism.
- Disconnect means, such as a switch or circuit breaker on the electrical panel, must be provided on the product's fixed power supply leads in accordance with the installation rules.
- If the product to be installed requires power supply of 230Vac or 110Vac, ensure that connection is to an electrical panel with ground connection.
- The product is only powered by low voltage safety with control board (only at 24V motors).
- Parts/products weighing more than 20 kg must be handled with special care due to the risk of injury. It is recommended to use suitable auxiliary systems for moving or lifting heavy objects.
- Pay special attention to the danger of falling objects or uncontrolled movement of doors/gates during the installation or operation of this product.

WARNINGS FOR USERS

- Keep this manual in a safe place to be consulted whenever necessary.
- If the product has contact with fluids without being prepared, it must immediately disconnect from the power supply to avoid short circuits, and consult a specialized technician.
- Ensure that technician has provided you the product manual and informed you how to handle the product in an emergency.
- If the system requires any repair or modification, unlock the automatism, turn off the power and do not use it until all safety

conditions have been met.

- In the event of tripping of circuits breakers or fuse failure, locate the malfunction and solve it before resetting the circuit breaker or replacing the fuse. If the malfunction is not repairable by consult this manual, contact a technician.
- Keep the operation area of the motorized gate free while the gate in in motion, and do not create strength to the gate movement.
- Do not perform any operation on mechanical elements or hinges if the product is in motion.

RESPONSABILITY

- Supplier disclaims any liability if:
 - Product failure or deformation result from improper installation use or maintenance!
 - Safety norms are not followed in the installation, use and maintenance of the product.
 - Instructions in this manual are not followed.
 - Damaged is caused by unauthorized modifications
 - In these cases, the warranty is voided.

MOTORLINE ELECTROCELOS SA.

Travessa do Sobreiro, nº29
4755-474 Rio Côvo (Santa Eugénia)
Barcelos, Portugal

SYMBOLS LEGEND:



• Important safety notices



• Useful information



• Programming information



• Potentiometer information



• Connectors information



• Buttons information

02. AUTOMATISM

TECHNICAL CHARACTERISTICS

ZUMA is an electromechanical barrier developed to control vehicle access to private, industrial or commercial areas.

Automatism technical specifications:

	ZUMA 4	ZUMA 6	ZUMA 8
• Operating power	150W		200W
• Barrier Power supply	110/230Vac 50/60Hz		
• Motor voltage	24Vdc		
• Noise	LpA <= 50dB (A)		
• Operating temperature	-20°C to 50°C		
• Protection Class	IP54		
• Working Frequency	50%		
• Rotational Speed	61 RPM		42 RPM
• Number of springs	1	2	3
• Opening speed	5 sec.	5 sec.	8 sec.

INSTALLATION COMPONENTS

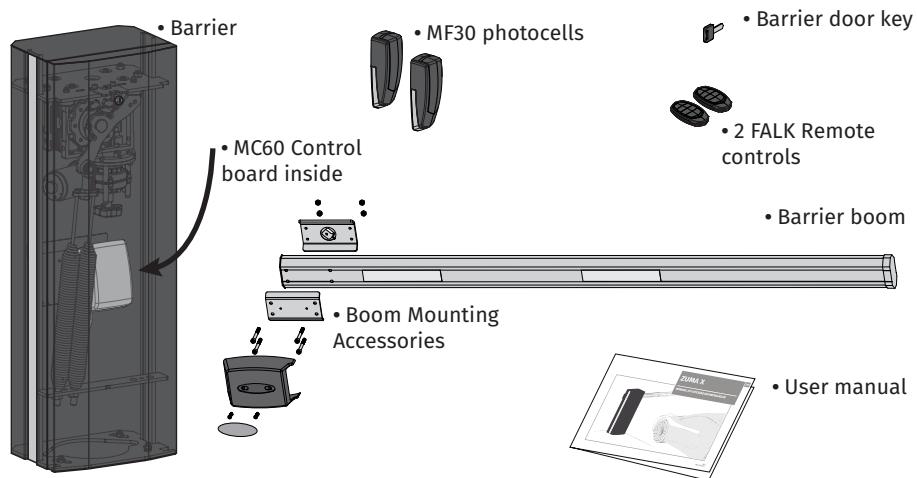

Some of these accessories may be sold separately. Consult your distributor.

02. AUTOMATISM

DIMENSIONS

• SPAT FIXED

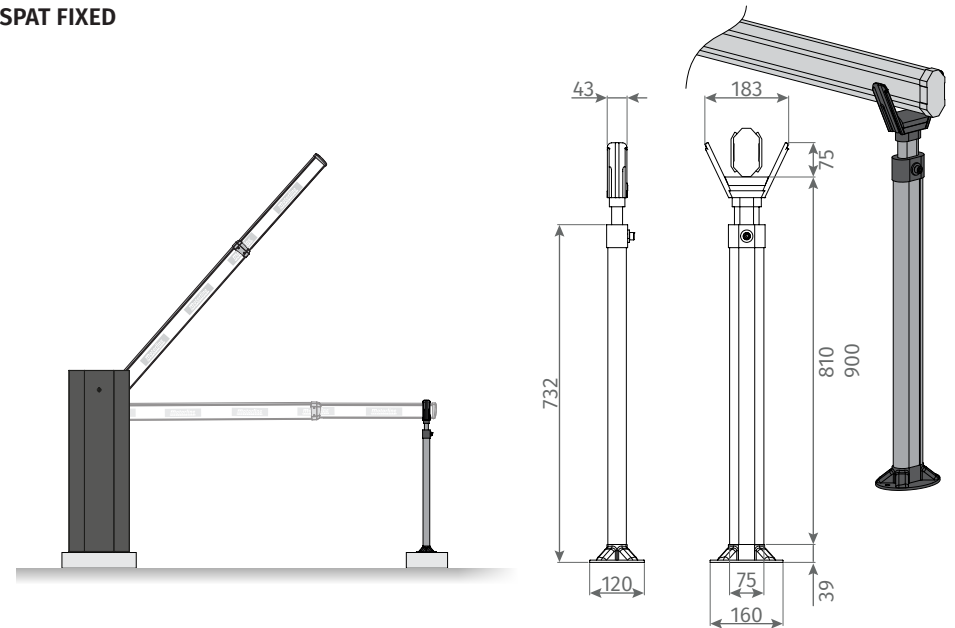

• SPAT MOBILE

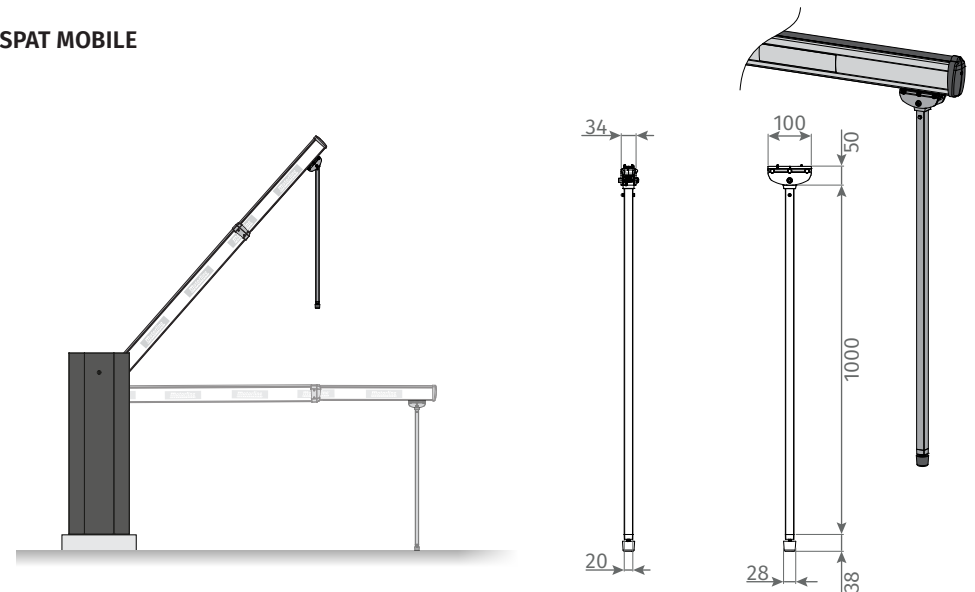

02. AUTOMATISM

DIMENSIONS

• ZUMA 4 / ZUMA 6 (Dimensions in mm)

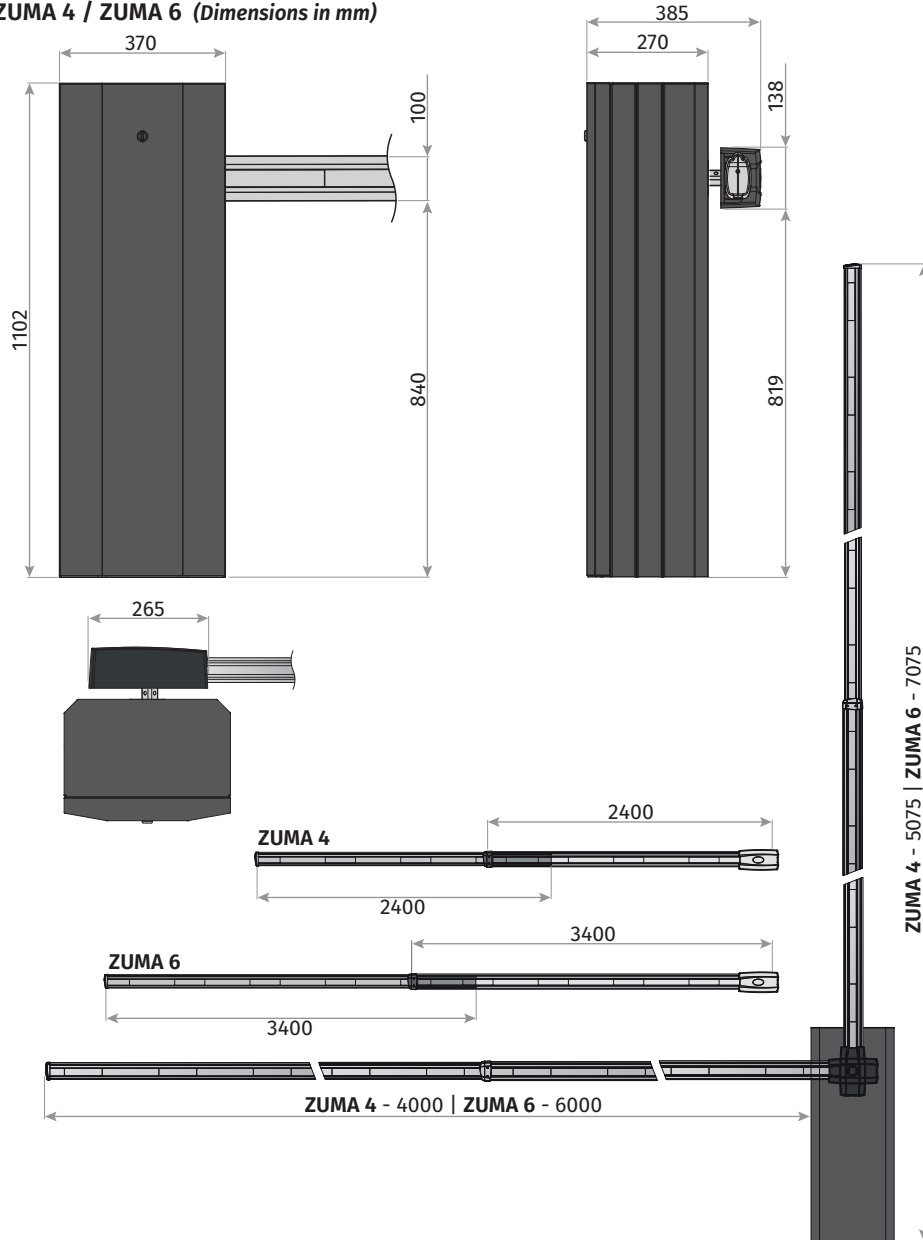

• ZUMA 8 (Dimensions in mm)

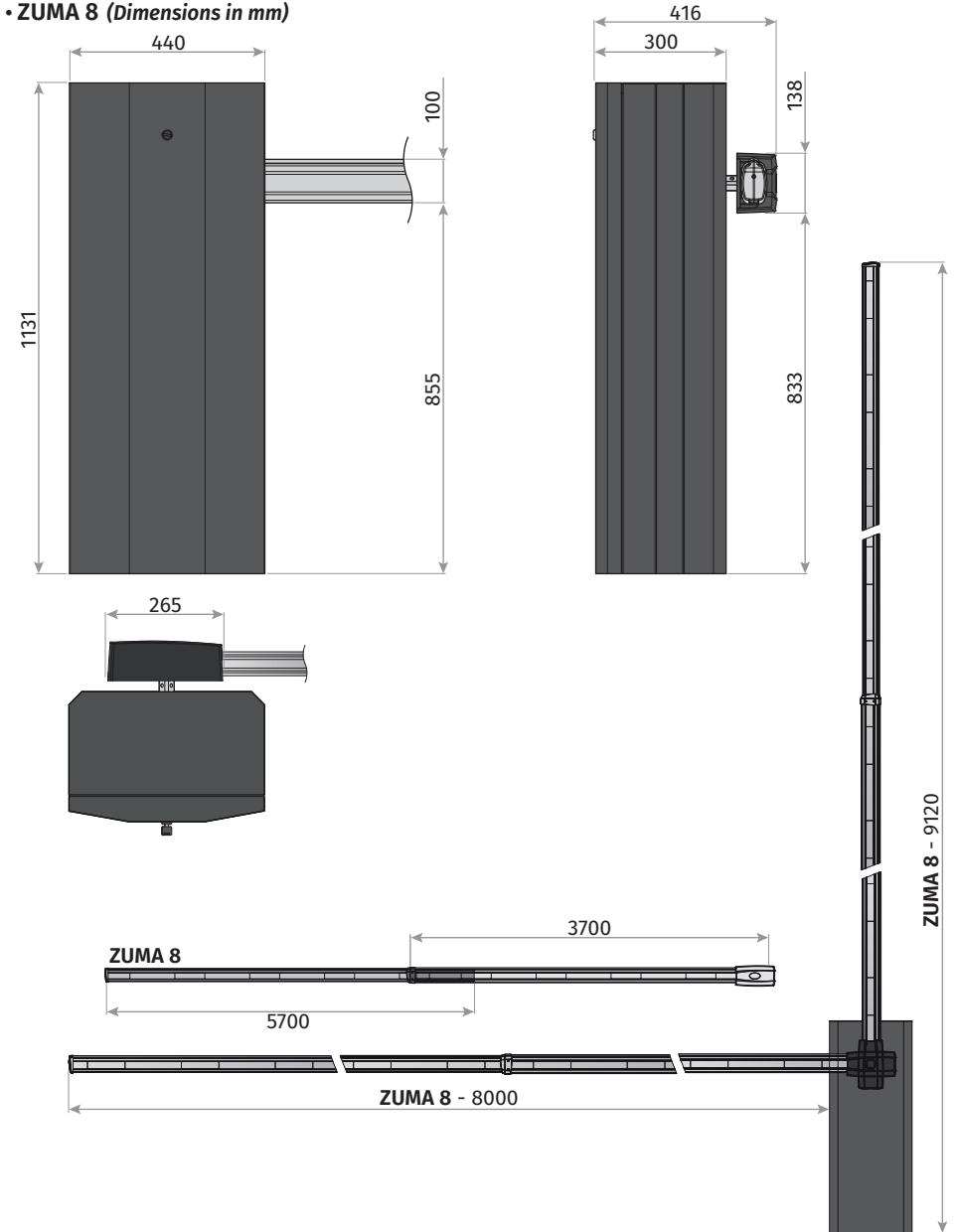

02. AUTOMATISM

DIMENSIONS

• ZUMA 4 / ZUMA 6 (Dimensions in mm)

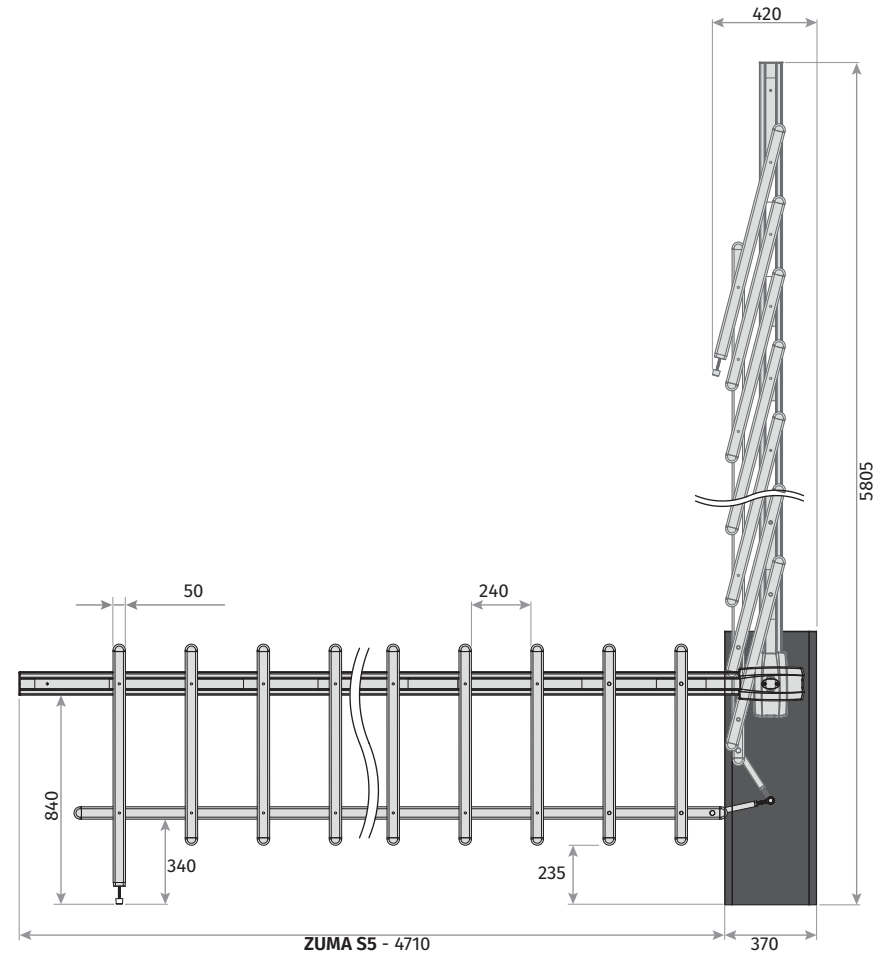
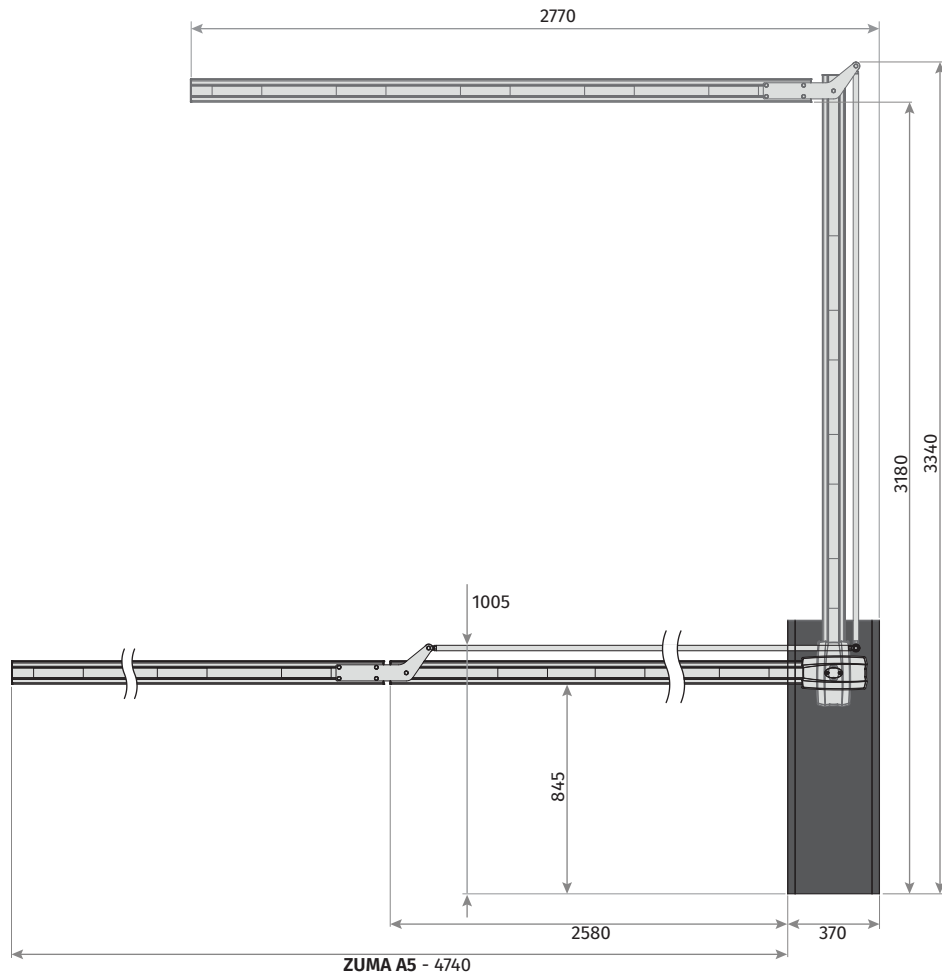

02. AUTOMATISM

DIMENSIONS

• ZUMA 8 (Dimensions in mm)

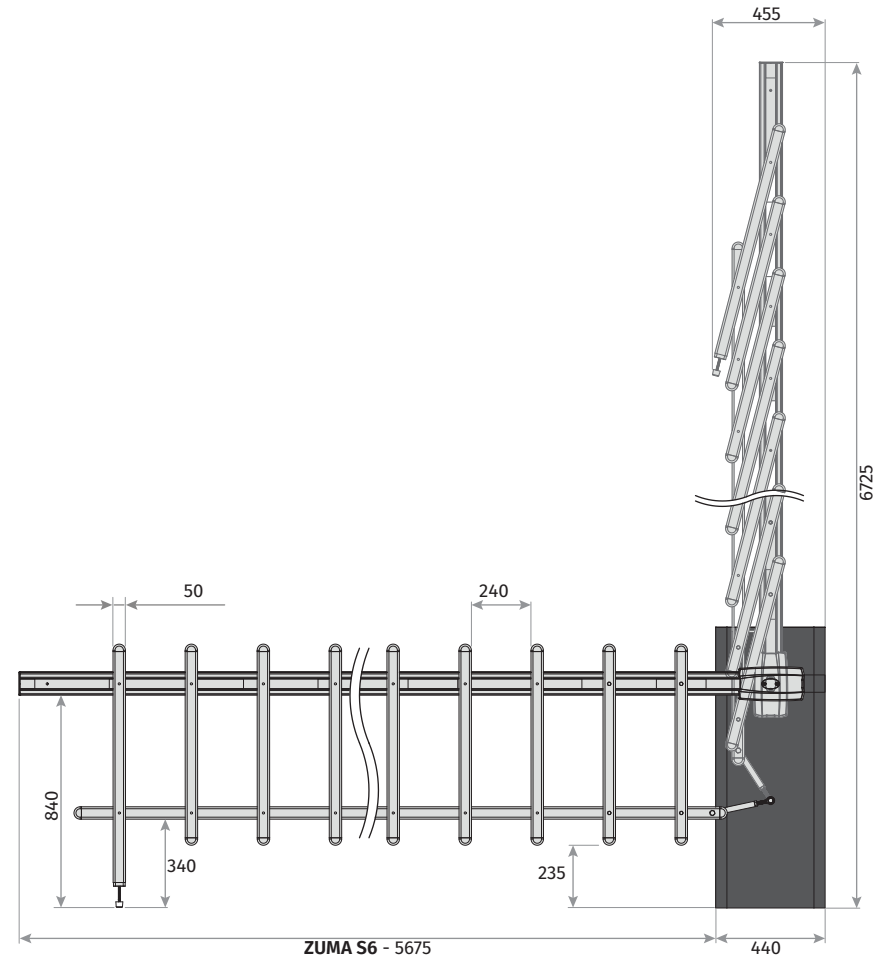
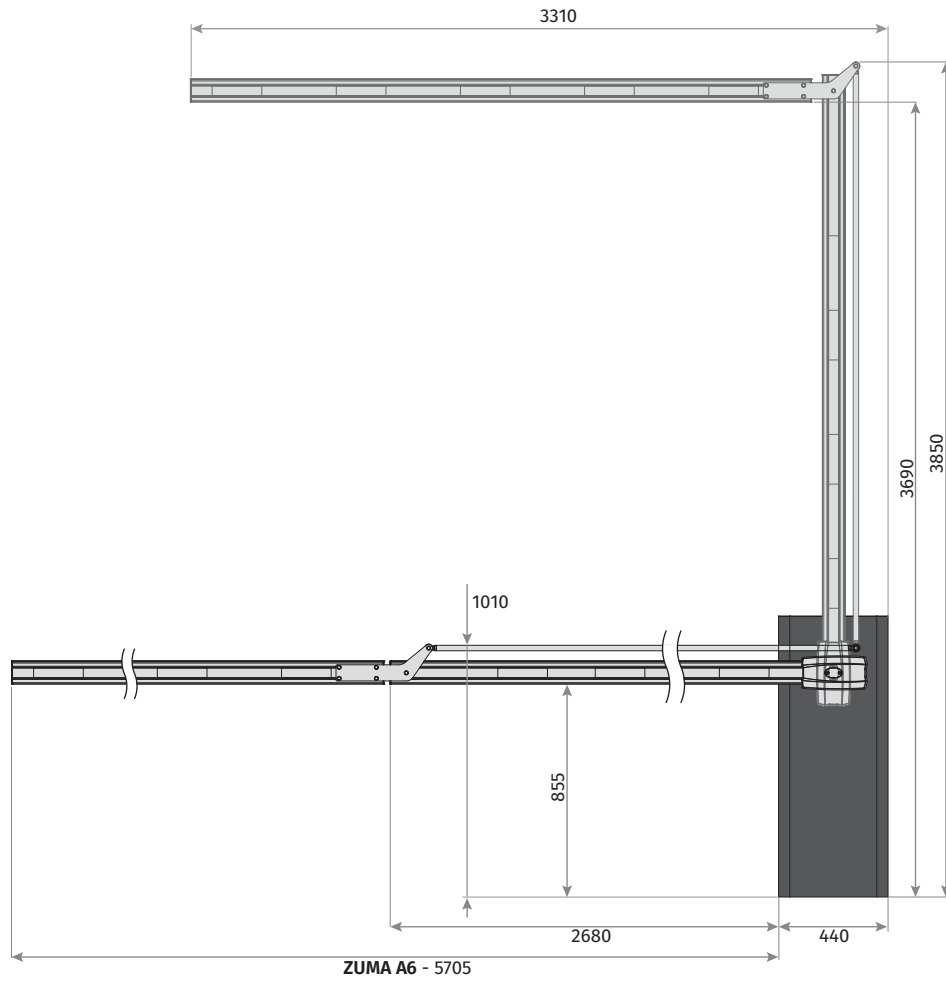

02. AUTOMATISM

REMOVE THE DOOR

This barrier allows free access to the interior, to facilitate the installation and maintenance process of the product. To do this, you must remove the front door.

1 UNLOCK THE DOOR

Insert the key into the outer lock and turn it 90° to unlock the door.

2 REMOVE THE DOOR

Carefully slide the door up to separate it from the barrier body.

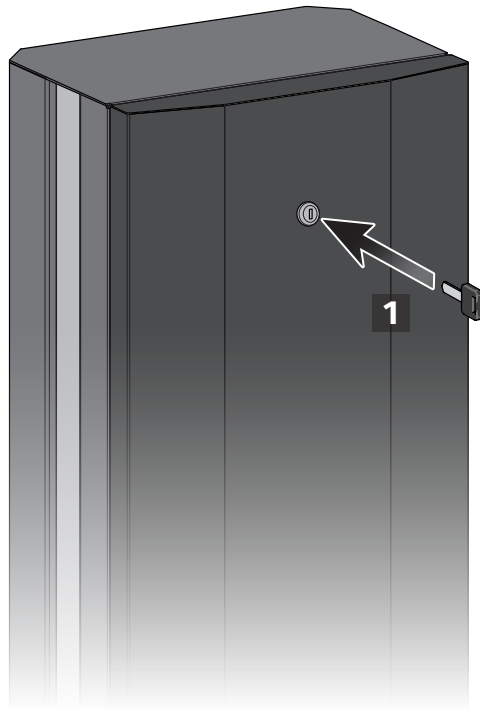

Slide the door in a movement parallel to the barrier body.

02. AUTOMATISM

MANUAL OPENING / CLOSING

In case of an emergency or during the installation/adjustment phase of the barrier, it may be necessary to move the boom manually. To manually open/close the barrier, follow the instructions below:



Under no circumstances should you place your hands on the motor movement axis and springs when the barrier is connected to the power supply.

1 REMOVE THE DOOR

Remove the barrier door to access the interior (see page 8A).

2 UNLOCK THE BARRIER

Push the crank in, turn 65° to the left.

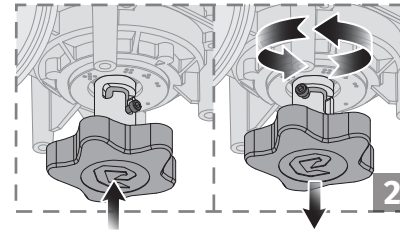

3 RAISE/LOWER BOOM

With the motor in the unlocked position, simply turn the crank to raise or lower the boom.

4 BLOCK THE BARRIER

Turn the crank until it comes out, or do the opposite movement as in Point 2.

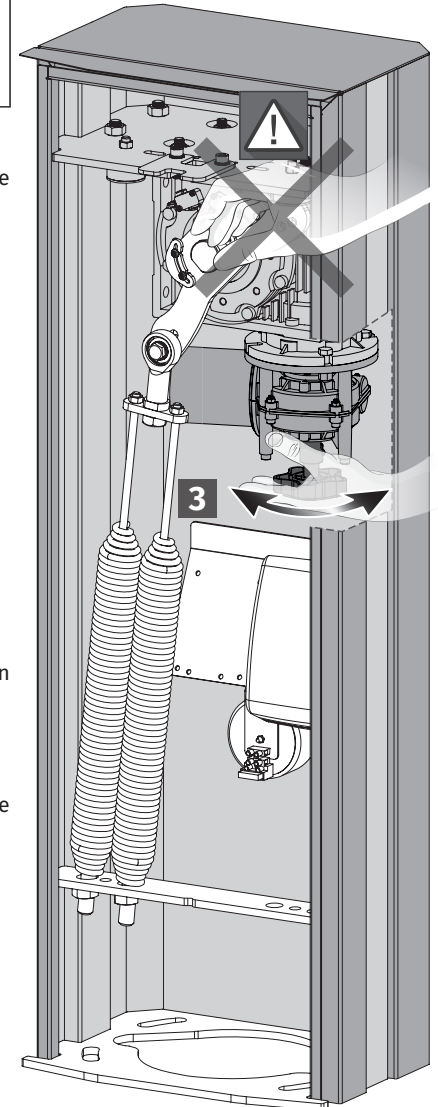
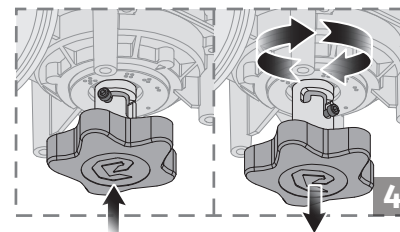

03. INSTALLATION

INSTALLATION MAP

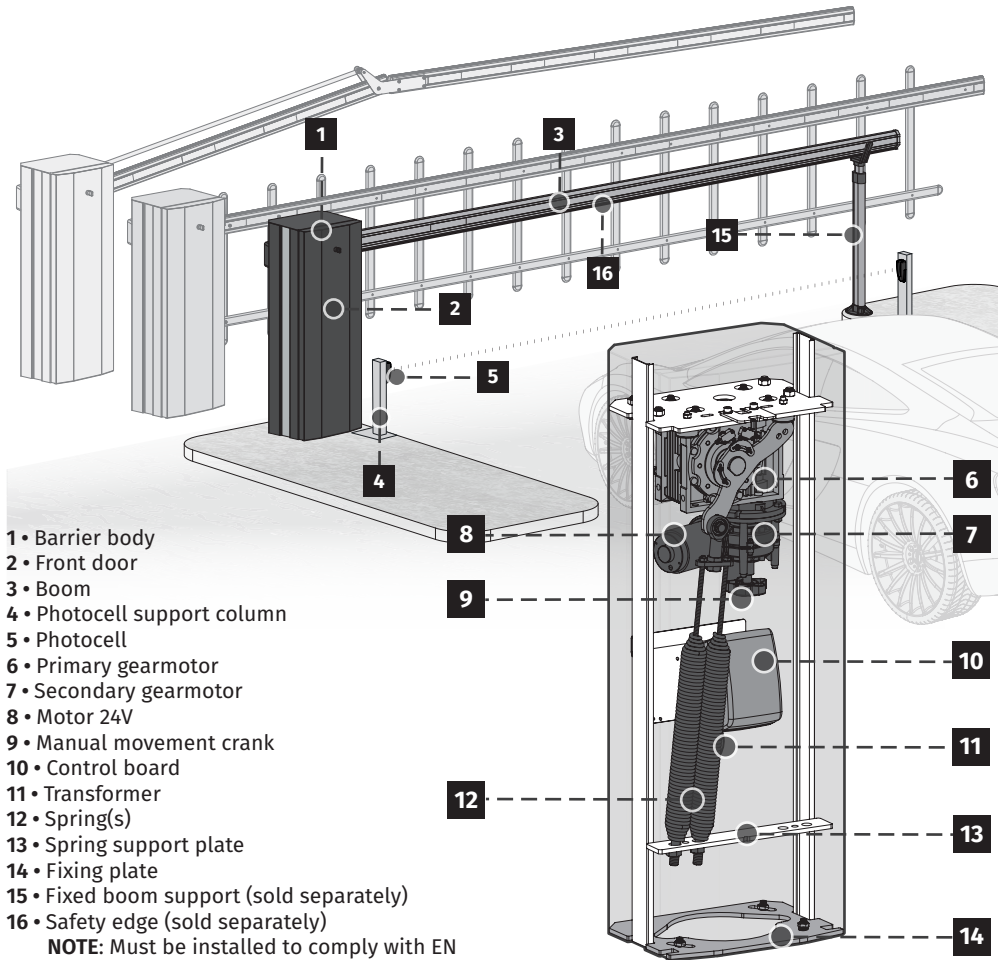

- 1 • Barrier body
- 2 • Front door
- 3 • Boom
- 4 • Photocell support column
- 5 • Photocell
- 6 • Primary gearmotor
- 7 • Secondary gearmotor
- 8 • Motor 24V
- 9 • Manual movement crank
- 10 • Control board
- 11 • Transformer
- 12 • Spring(s)
- 13 • Spring support plate
- 14 • Fixing plate
- 15 • Fixed boom support (sold separately)
- 16 • Safety edge (sold separately)

NOTE: Must be installed to comply with EN 12978:2003+A1:2009 Industrial, commercial and garage doors and gates - Safety devices for power operated doors and gates - Requirements and test methods.



Some of these components can be sold separately. Consult your distributor.



Use rigid and/or flexible tubs, suitable for the installation of electrical cables. Always separate low voltage cables from 230Vac cables to avoid any interference. The map shown is for a standard installation, however we do not provide all components (see kit composition on page 4A). If you need other accessories please contact us.

03. INSTALLATION

FOUNDATION

• CREATE FOUNDATION

- 1 Make a hole 400mm (or greater) in depth and with the following measurements:
ZUMA 4 | ZUMA 6: 370(A) x 470(B)mm;
ZUMA 8: 400(A) x 550(B)mm.
- 2 Fill with concrete and smooth the top.
- 3 Apply the barrier to the foundation, with the fixing bolts in place, to ensure they are securely fixed (see page 10).

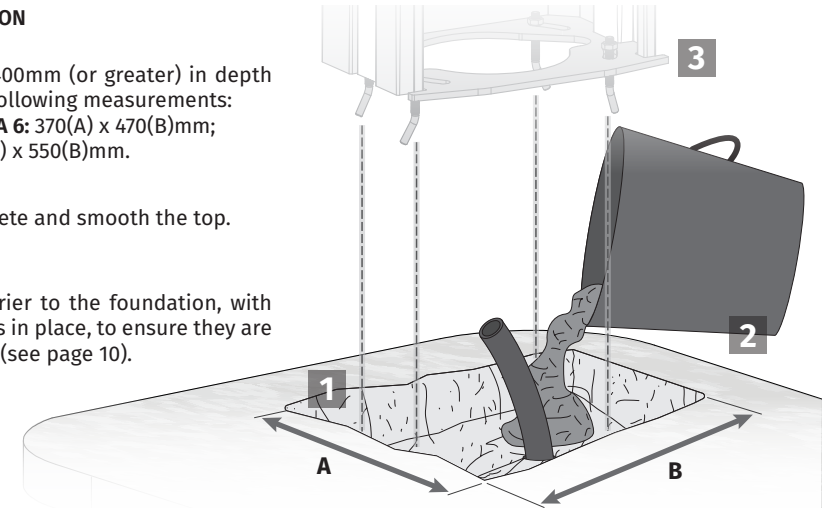

• EXISTING FOUNDATION

**If you already have a foundation created, proceed as follows:*

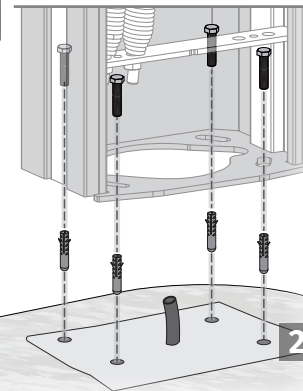

- 1 Position the barrier on the foundation to mark the holes. Make the markings in the center of the holes as in the image below.

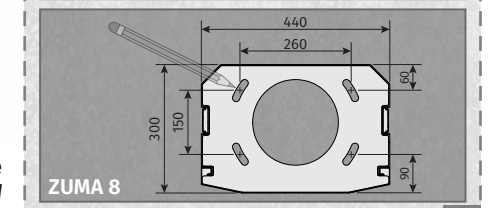
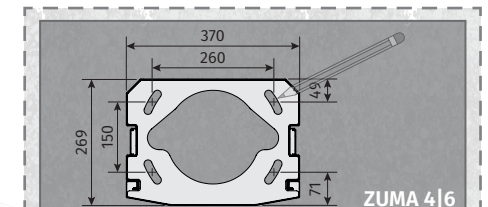

*Dimensions in mm

- 2 Remove barrier and drill holes.

- 3 Position the barrier and secure it using the indicated dowels and screws (**not included in the kit**).

03. INSTALLATION

AUTOMATISM INSTALLATION

1 Assemble the nuts and bolts in the center of the holes in the base of the barrier as shown in the drawing.

2 Check that the foundation is perfectly level before applying the barrier.

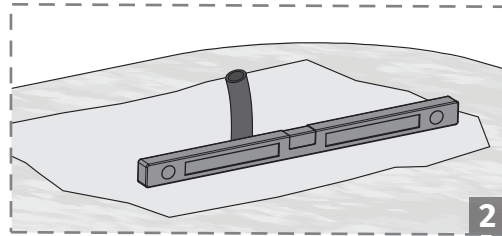

3 While the cement is still fresh, apply the barrier ensuring that the screws and nuts enter at least 200mm into the cement.

**If you are installing the barrier on an existing foundation, screw the barrier using screws and dowels as shown on page 9B (not supplied in the kit).*

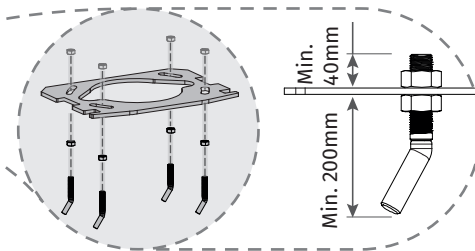
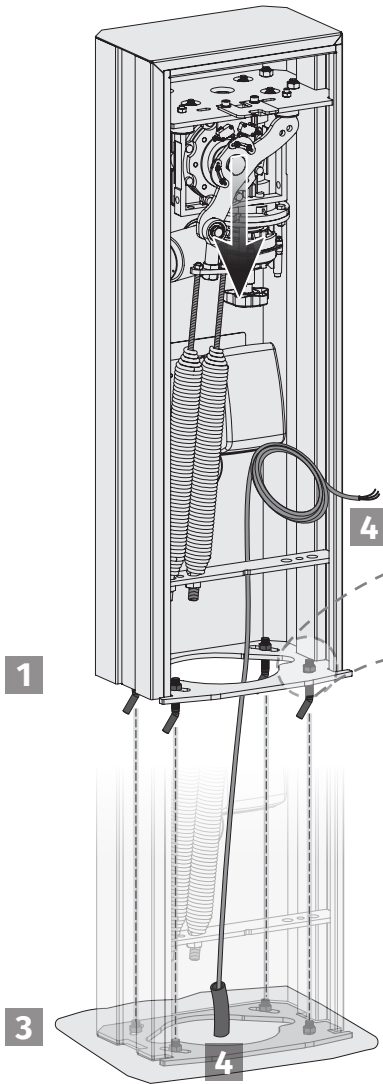

i Note: The nuts and bolts are not supplied in the kit.

4 Pass the electrical cables to connect the motor to accessories and power. Leave cables with a length that ensures an easy connection to the control board (positioned at half the total height).

! CEMENT MUST BE FRESH IN STEP 3



• ADJUST BARRIER POSITION

**Once fixed to the ground, the ZUMA is prepared to allow a position adjustment of a few millimeters. Adjustment is made by rotating the barrier in relation to its center.*

- 1 Give some slack to the tightening nuts of the plate in order to be able to rotate the barrier.
- 2 Rotate the barrier to the right or left to place it at the desired point.

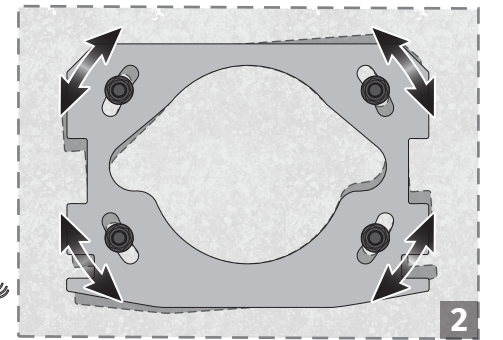

3 Re-tighten the nuts to secure the barrier in the defined position.



This adjustment should only be made when the cement of the foundation is dry in order to avoid displacement of the barrier.

03. INSTALLATION

SPRING POSITION

• BOOM ON THE LEFT (SX)

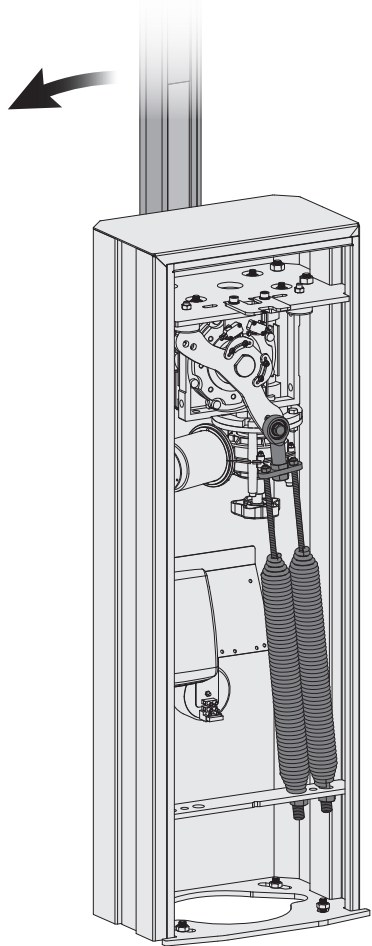

• Springs installed on the right side

• BOOM ON THE RIGHT (DX)

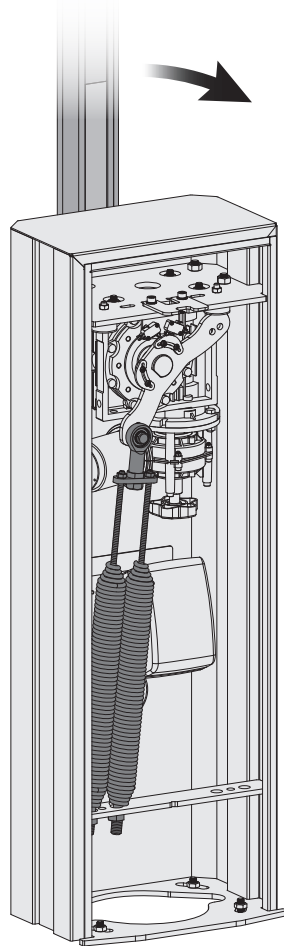

• Springs installed on the left side



If you order ZUMA without specifying the position of the boom, it will be mounted on the right (DX).
If the boom is not in the desired position, follow the instructions on page 12 to reverse the opening/closing direction.

03. INSTALLATION

AMOUNT OF SPRINGS

• ZUMA 8 (3 SPRINGS)

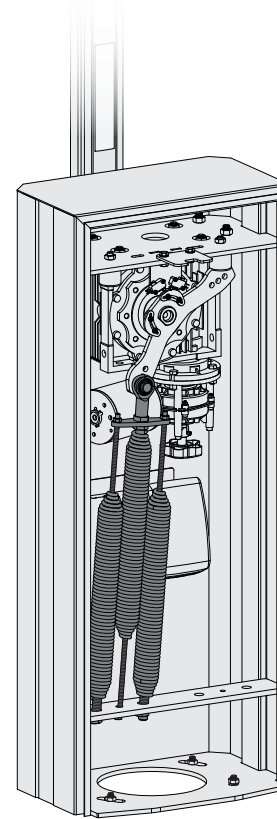

ADJUSTMENT:

- 2xM8 on top (joint bearing plate)
- 1xM8 at the bottom (structure plate)

FIXED SUPPORT:

- 2xM16 at the bottom (structure plate)
- 1xM16 on top (joint bearing plate)

• ZUMA 6 (2 SPRINGS)

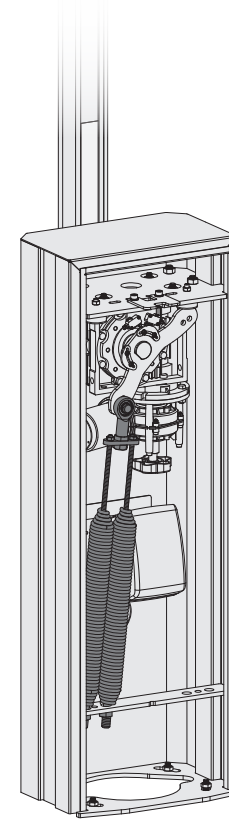

ADJUSTMENT:

- 2xM8 on top (joint bearing plate)

FIXED SUPPORT:

- 2xM16 at the bottom (structure plate)

• ZUMA 4 (1 SPRING)

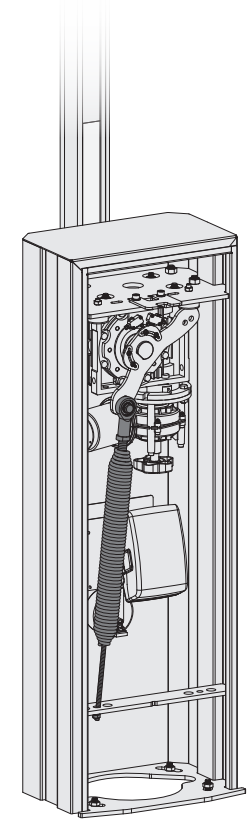

ADJUSTMENT:

- 1xM8 at the bottom (structure plate)

FIXED SUPPORT:

- 1xM16 on top (joint bearing plate)

03. INSTALLATION

INSTALLATION OF SPRINGS



If the springs are on the wrong side for the intended boom direction (see diagram on page 11A), you must reverse the position of the springs on the rotation lever.

To do this, you will have to:

- 1 - Unscrew the springs from the two support points;
- 2 - Tighten them again on the opposite side, respecting the adjustment table on page 19.



Whenever you carry out this process, you must check the motor connections to the control board and the limit switches, according to the diagram on page 22.

• REMOVE THE SPRINGS FROM THE LEVER

- 1 Unscrew the nut from screw on the back of the lever.
- 2 Loosen the screw and washers that secure the joint bearing to the lever.
- 3 Unscrew the adjusting nuts (lower part)

• ASSEMBLE THE SPRINGS ON THE OPPOSITE SIDE

- 4 Fix the spring joint bearing on the opposite side of the lever, tightening all components with the main screw, and then lock it with the nut behind the lever.
- 5 Fix the springs to the lower plate, using the nuts.

• REVERSE THE MOTOR CONNECTIONS

- 6 Check the connections of the motor wires to the control board (see control board manual)



When attaching the joint bearing, you must place it in the appropriate hole for the size of the boom you are going to use (see table on page 22).

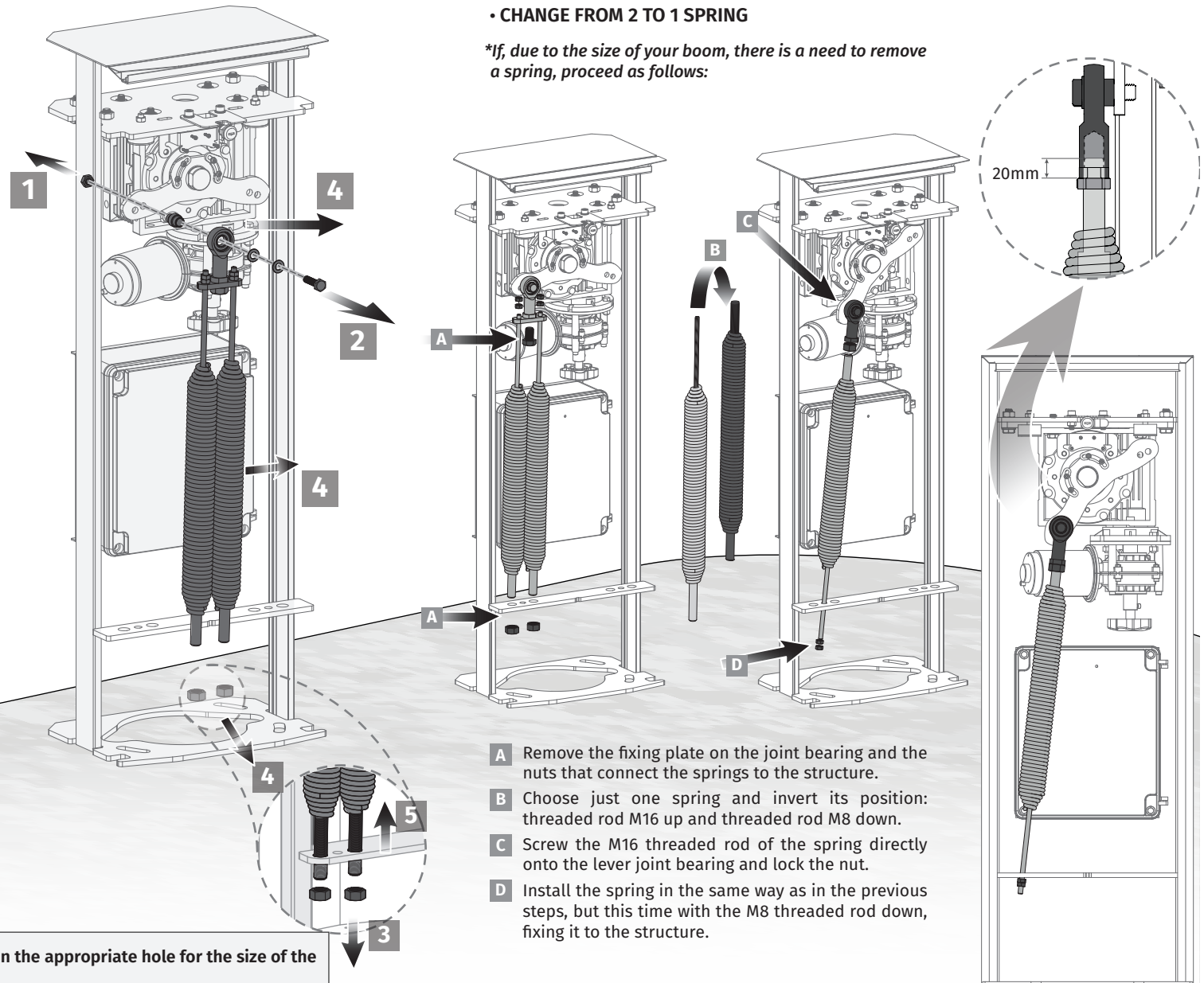

• CHANGE FROM 2 TO 1 SPRING

**If, due to the size of your boom, there is a need to remove a spring, proceed as follows:*

- A Remove the fixing plate on the joint bearing and the nuts that connect the springs to the structure.
- B Choose just one spring and invert its position: threaded rod M16 up and threaded rod M8 down.
- C Screw the M16 threaded rod of the spring directly onto the lever joint bearing and lock the nut.
- D Install the spring in the same way as in the previous steps, but this time with the M8 threaded rod down, fixing it to the structure.

03. INSTALLATION

BOOM ASSEMBLY (ZUMA 4 / ZUMA 6)



• CHECK BOOM SUPPORT POSITION

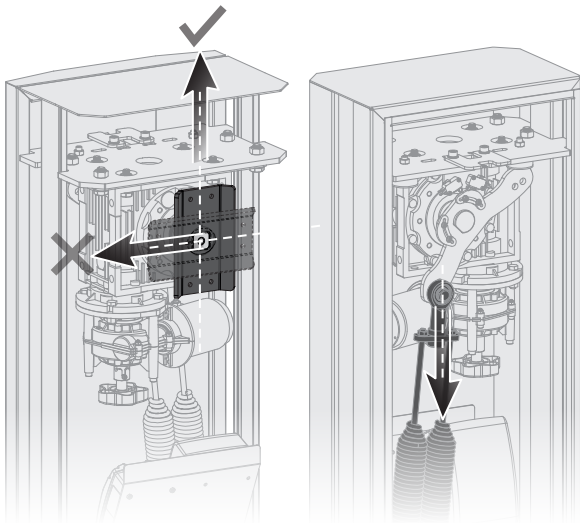

• Vertical plate

Before assembling the boom, check that:

- Springs are down (no tension)
- The boom support is on vertical position



If the springs are up (stretched), you can lower them using the hand crank (see page 8B)

If this situation does not occur, the boom support must be rotated:

- A • Loosen the screws on the boom support and disengage from the shaft;
- B • Refit the support on the shaft, this time in the vertical position;
- C • Tighten the two screws to secure.

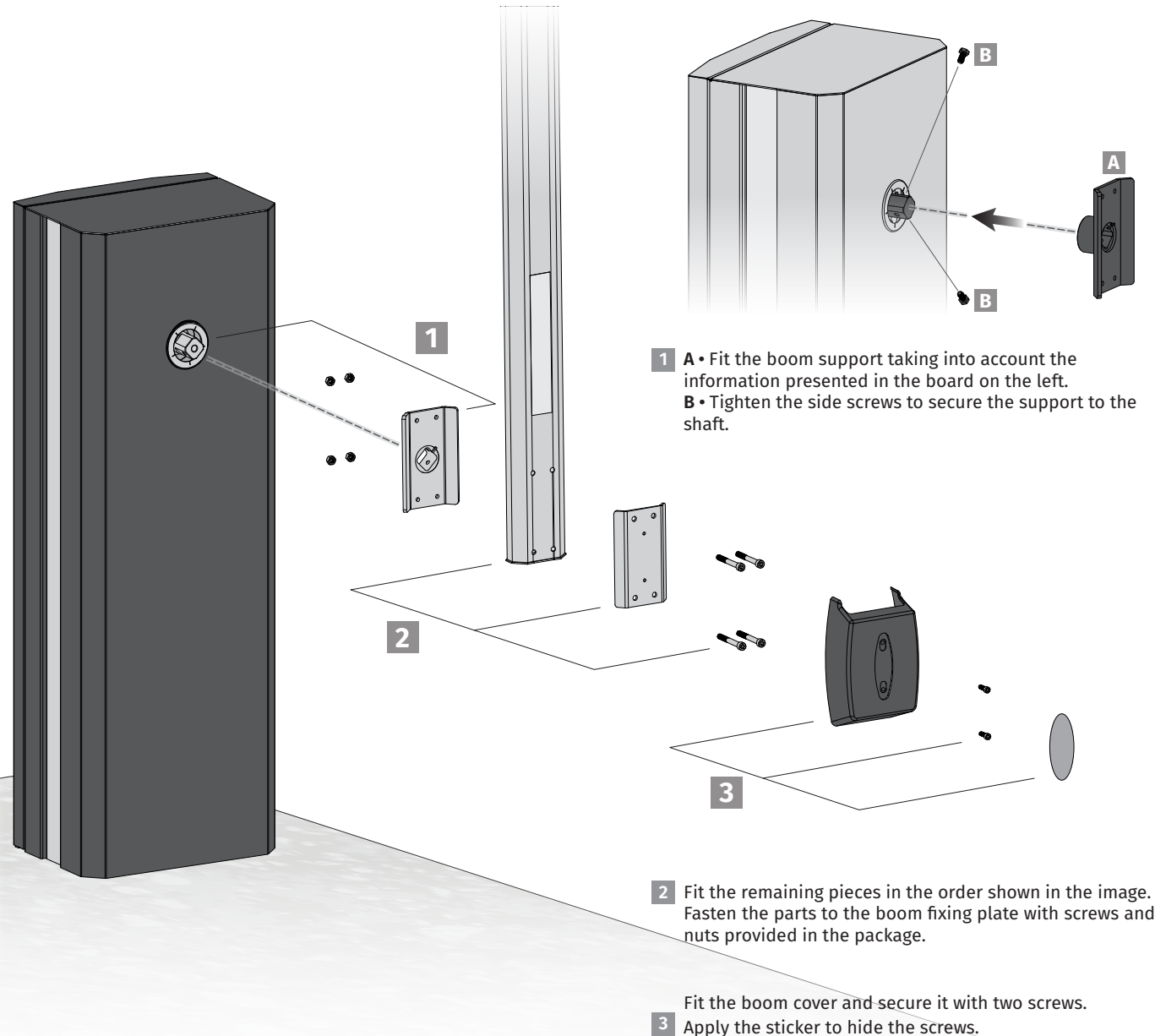

- 1 A • Fit the boom support taking into account the information presented in the board on the left.
B • Tighten the side screws to secure the support to the shaft.

- 2 Fit the remaining pieces in the order shown in the image. Fasten the parts to the boom fixing plate with screws and nuts provided in the package.

- 3 Fit the boom cover and secure it with two screws.
Apply the sticker to hide the screws.

03. INSTALLATION

INSTALLATION OF SPRINGS (ZUMA 8)



Follow the instructions indicated on page 12 and making the association with the numbers in the drawing below, proceed with the installation of the springs in the ZUMA 8.

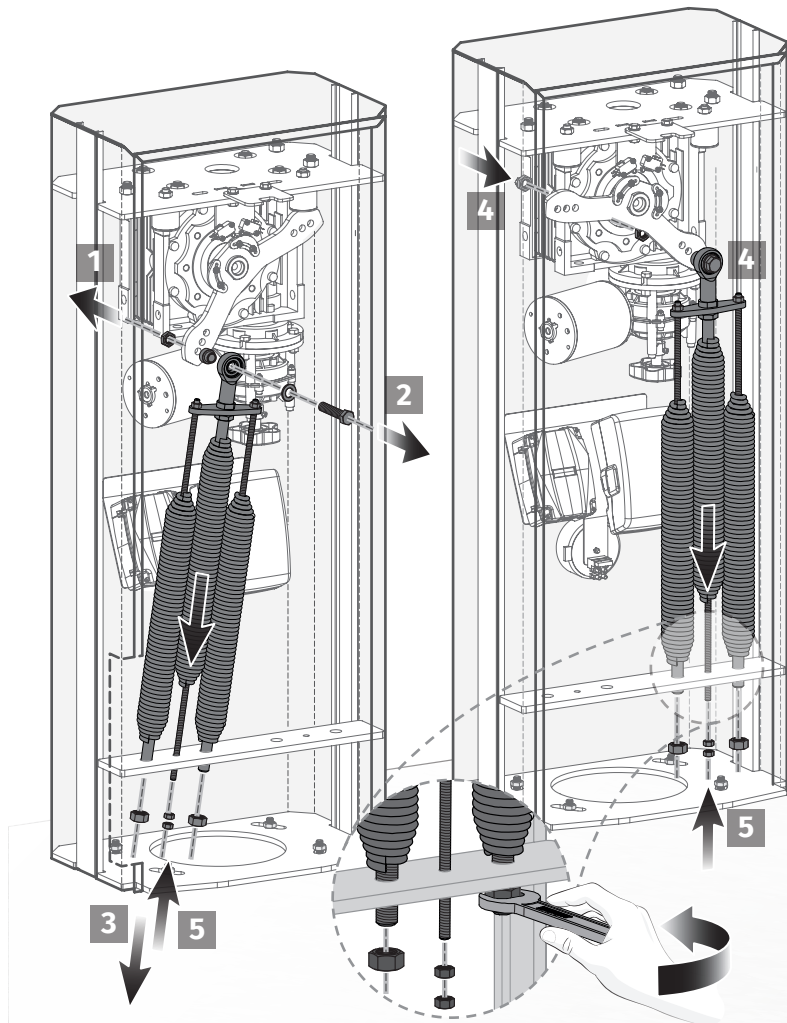

03. INSTALAÇÃO

BOOM ASSEMBLY (ZUMA 8)



Follow the instructions indicated on page 13 and making the association with the numbers in the drawing below, proceed with the assembly of the boom in the ZUMA 8.

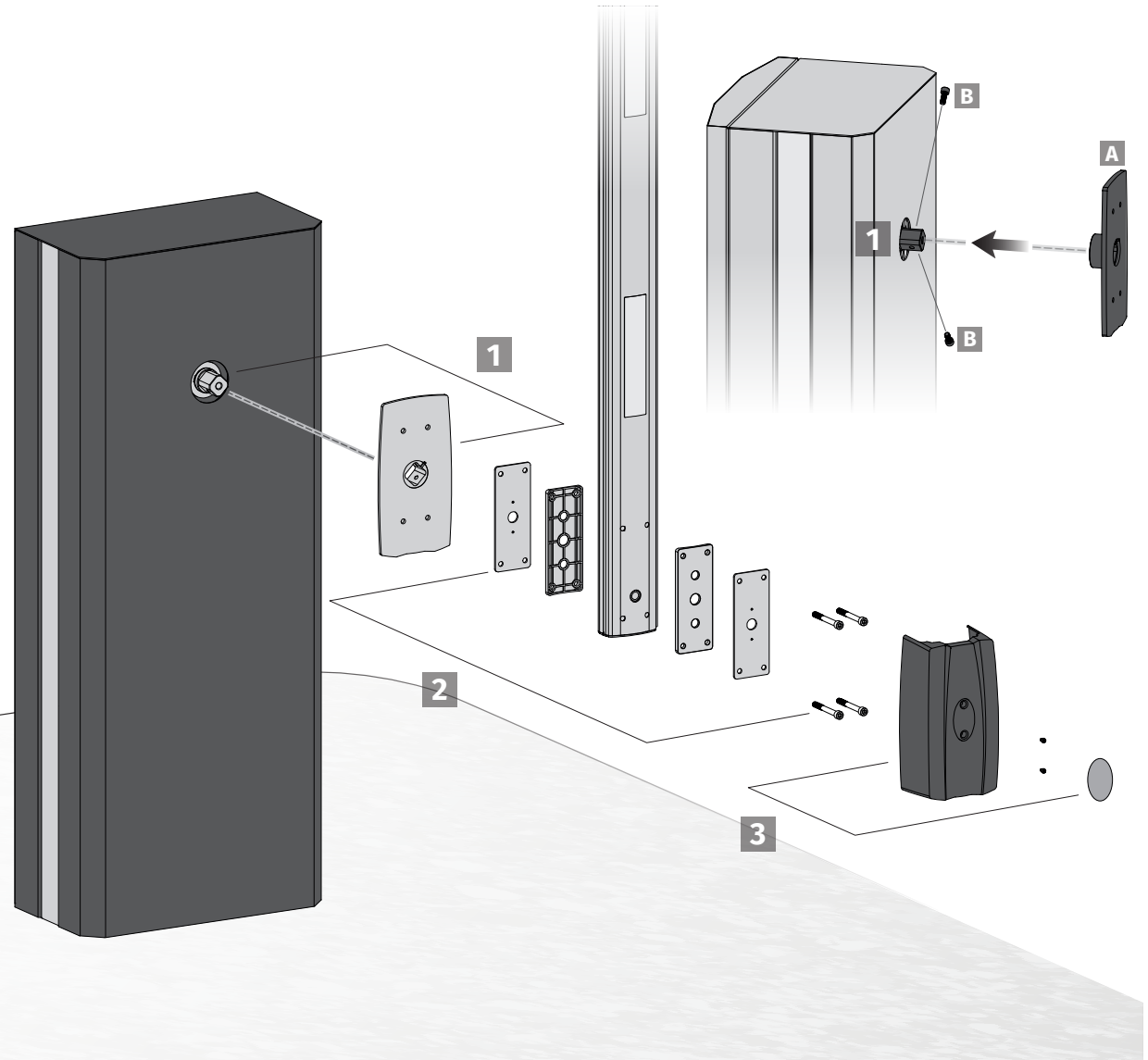

03. INSTALLATION

BOOM MOUNTING - S5 AND S6



Apply the same steps from page:
• 12 and 13 - to the ZUMA 4 and ZUMA 6 boom;
• 14 - to the ZUMA 8 boom;
And add step 5 to complete assembly.

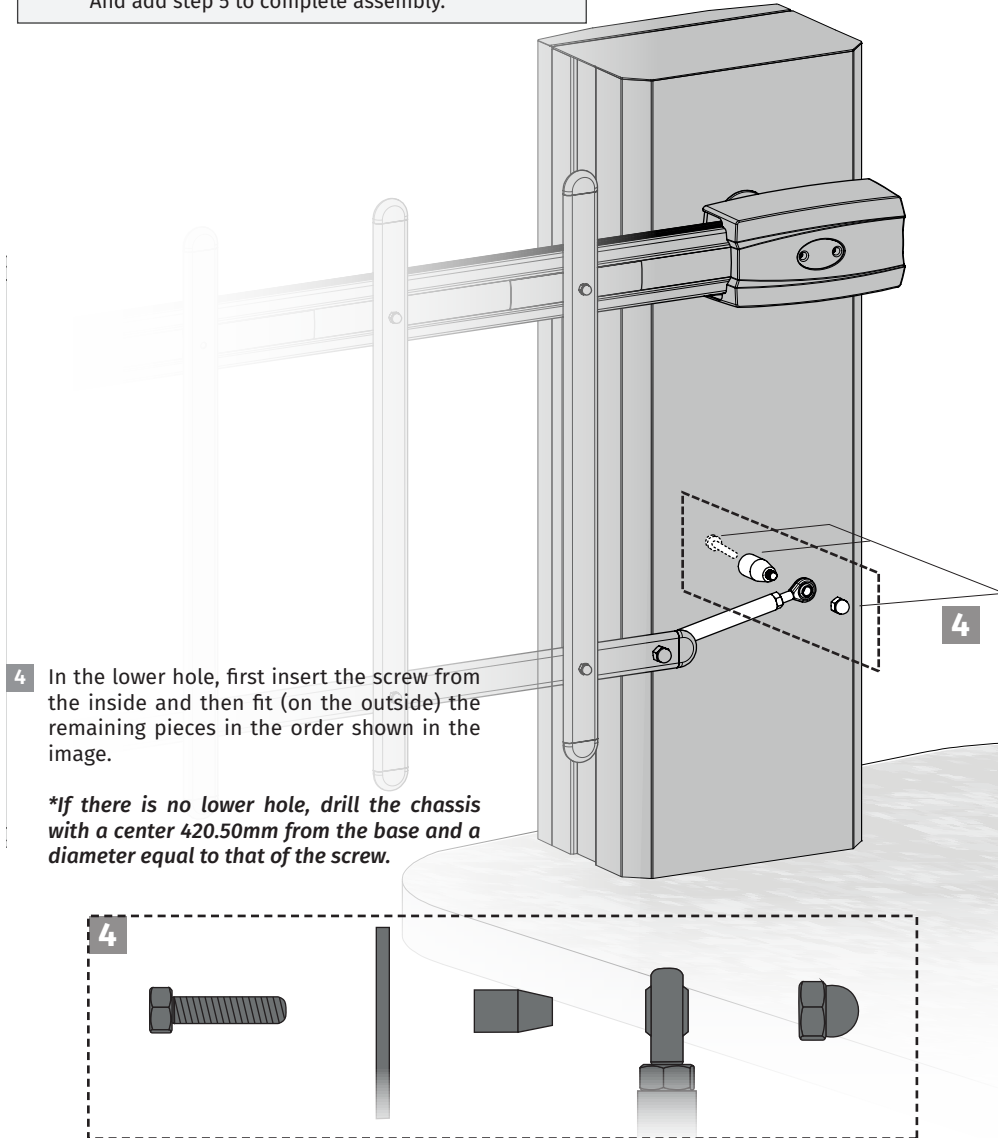

4 In the lower hole, first insert the screw from the inside and then fit (on the outside) the remaining pieces in the order shown in the image.

**If there is no lower hole, drill the chassis with a center 420.50mm from the base and a diameter equal to that of the screw.*

03. INSTALAÇÃO

BOOM MOUNTING - A5 AND A6



Apply the same steps from page:
• 12 and 13 - to the ZUMA 4 and ZUMA 6 boom;
• 14 - to the ZUMA 8 boom;
And add step 5 to complete assembly.

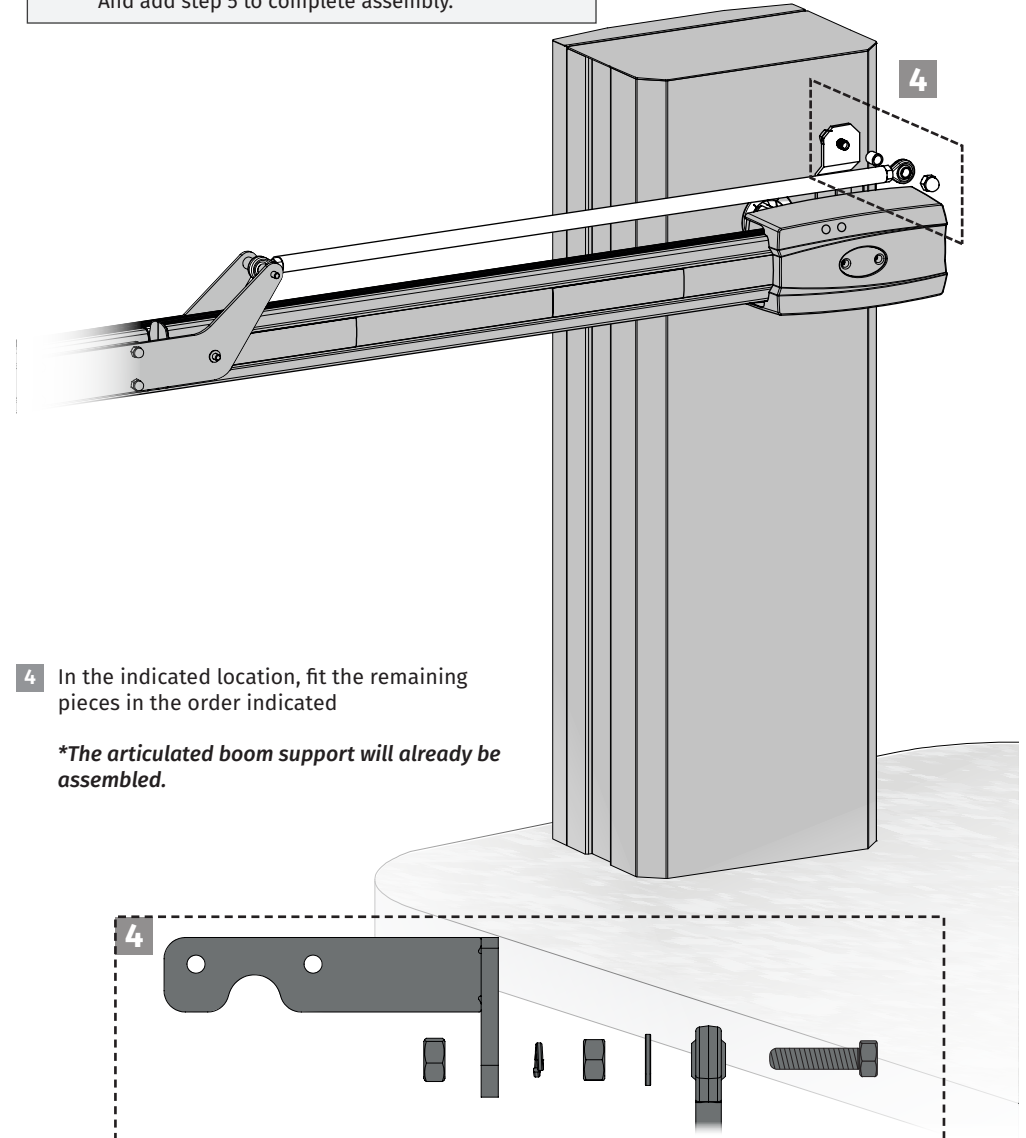

4 In the indicated location, fit the remaining pieces in the order indicated

**The articulated boom support will already be assembled.*

03. INSTALLATION

FIXING BOOM SUPPORTS

• DEFINE EXTENDABLE BOOM LENGTH

- 1 You must now establish the length of it so that you can then place the support, as shown in the image below.
The boom must exceed the position of the support arm by 50mm.

- 2 After placing the boom with the desired length, secure it with the two self-tapping screws on the fixed part of the boom.

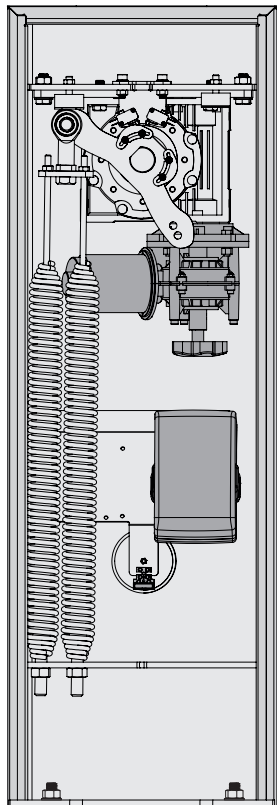
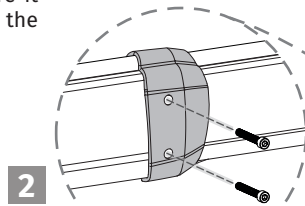

• APPLICATION OF BOOM SUPPORT (FIXED)

Once the length of the boom is established, define the location of fixing the boom support to the ground.

- 3 Drill two holes at the installation site to secure the support with screws and dowels.
- 4 Frame the support holes in the screws already placed and tighten with the nuts.
- 5 Attach the nuts' protective caps.

• ADJUST SUPPORT (FIXED) HEIGHT

If the height of the support arm is not adjusted to the height of the boom, you will need to adjust the height of the arm. To do this, follow these steps:

- 6 Loosen the locking stud of the support arm with a hex wrench.
- 7 Raise or lower the arm to place the support at the height needed to support the barrier.
- 8 Tighten the locking stud of the support arm to lock it in the set position.
If the screw is not enough to lock the support in the desired position, you must use a self-tapping screw in order to go through the two profiles to lock the height of the support.

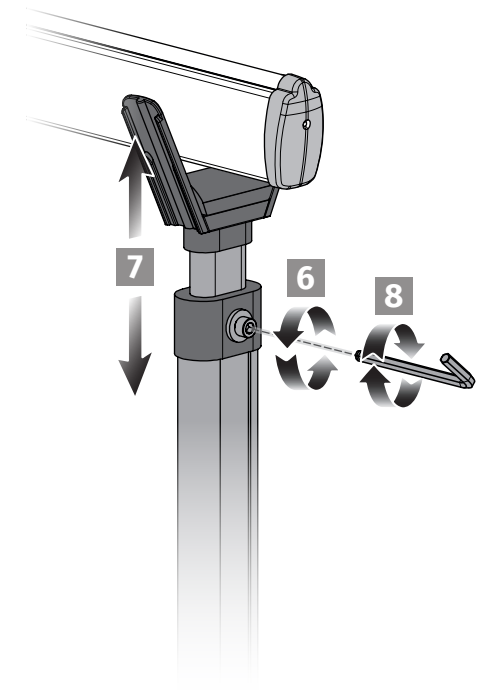
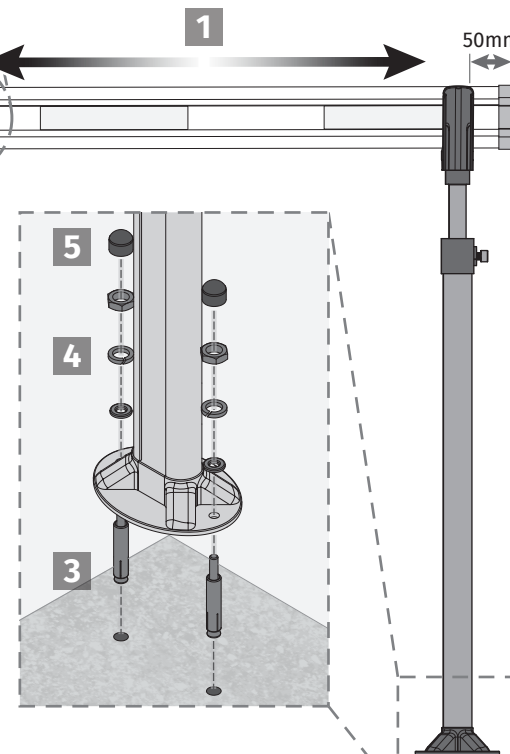

03. INSTALLATION

ADJUSTMENT OF THE BOOMS

• ADJUST MOBILE SPAT

If the floor is uneven or you want to adjust the edge height, you will need to adjust the floor stopper. To do this, follow the following steps:

- 1 Unscrew the screw securing the boom cap and remove it.
- 2 Fit the mobile steun into the slot at the bottom of the boom.
- 3 Secure the boom in place with two screws.
- 4 Replace the boom cap and tighten the screw.
- 5 Detach the base from the mobile spat. It may be necessary to remove side screws.
- 6 Tighten or loosen the adjustment screw located at the top of the floor stopper.
- 7 Put everything back together and test if it is as expected. Repeat if necessary. **Use Glue and Seal to fix the floor stopper to the Spat.**

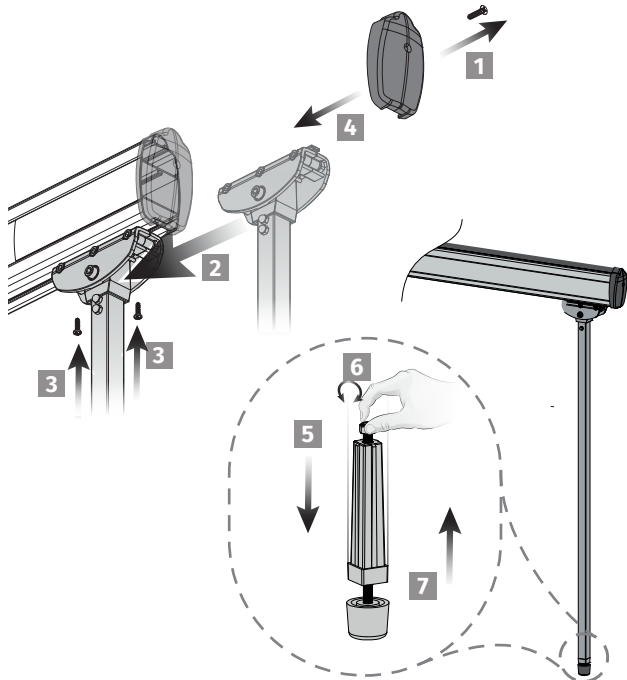

• ADJUST XS5 BOOM

Turn the crank (highlighted below) if you want to adjust the vertical profiles inserted into the boom slightly to the left or right.

• ADJUST XS5 MOBILE SPAT

If the floor is uneven or you want to adjust the edge height, you will need to adjust the floor stopper. To do this, follow the following steps:

- 1 Detach the base from the mobile spat. It may be necessary to remove side screws.
- 2 Tighten or loosen the adjustment screw located at the top of the floor stopper.
- 3 Put everything back together and test if it is as expected. Repeat if necessary. **Use Glue and Seal to fix the floor stopper to the Spat.**

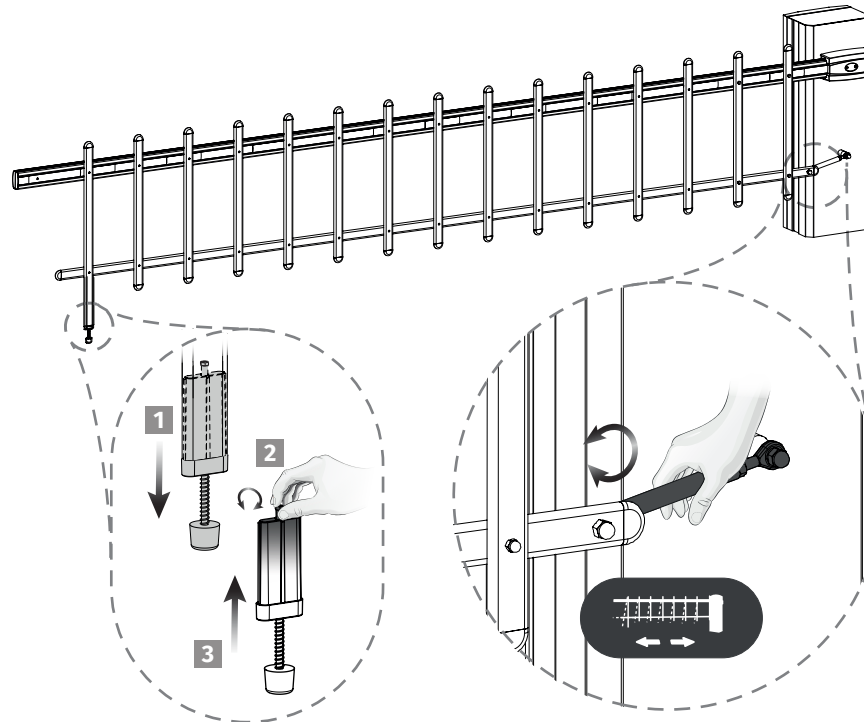

• ADJUST XA5 BOOM

Turn the crank (highlighted below) if you want to adjust the boom end slightly up or down. You can do the same process with the boom at the bottom or at the top.

NOTE: The 'L' lengths must be exactly the same.

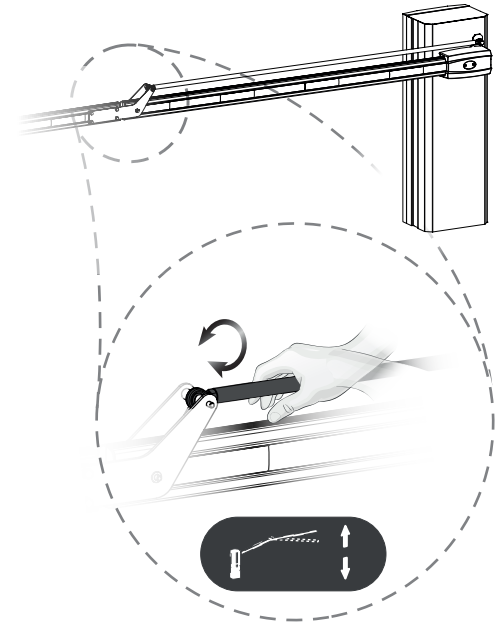
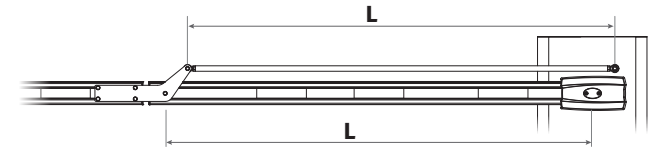

03. INSTALLATION

ADJUST THE SPRINGS

Before adjusting the springs, manually place the boom in the vertical position so that the springs are in the position of least tension (see page 8B).

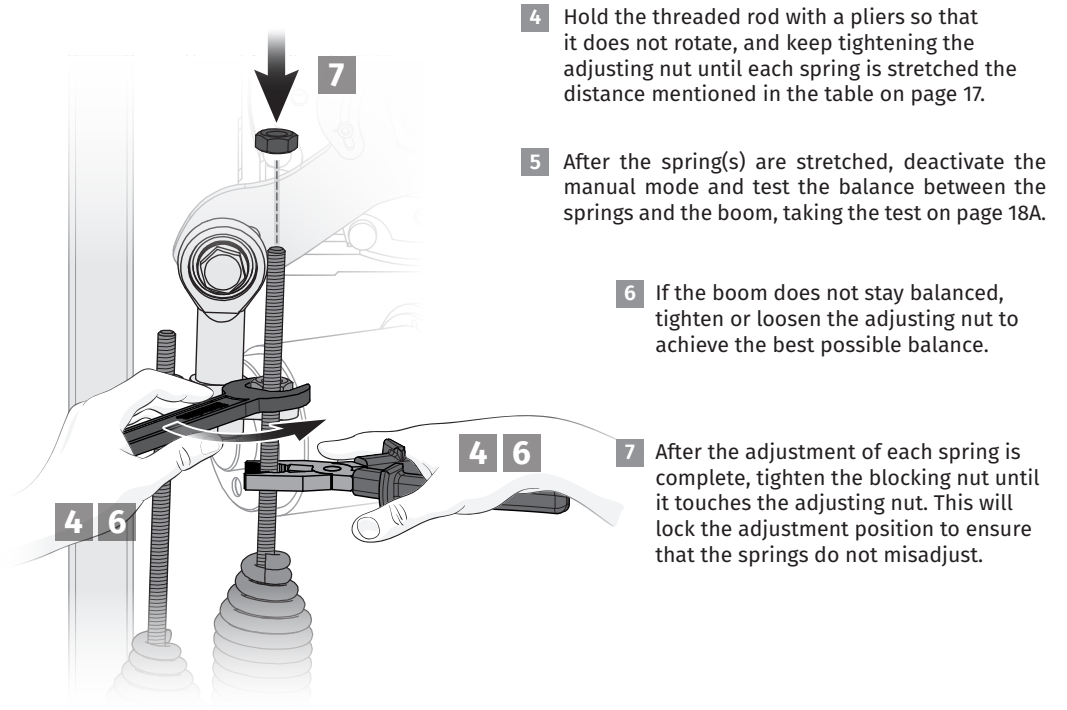
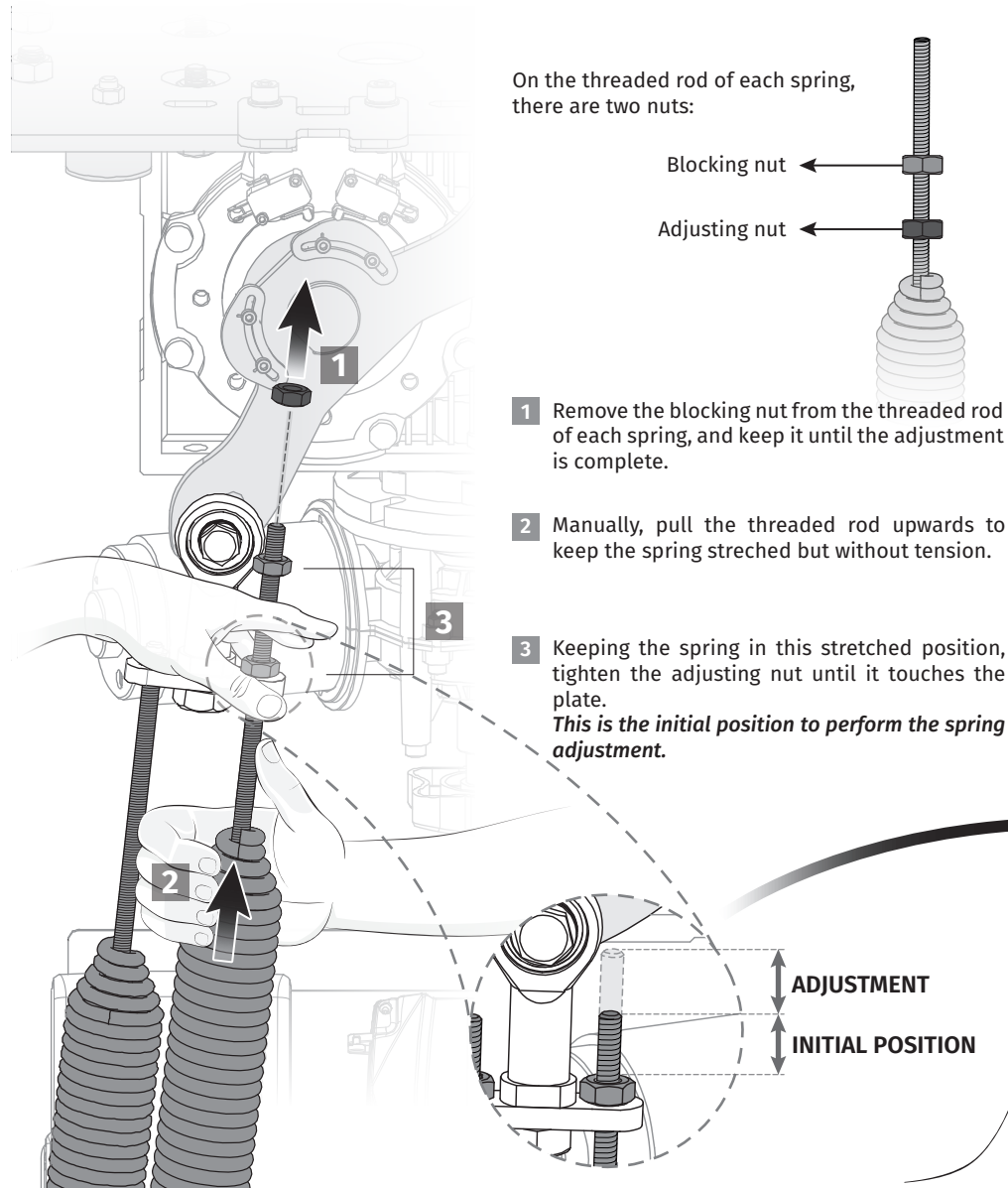

i • ADJUSTMENT EXAMPLE

**In this example, a 5.5M BOOM WITH RUBBER AND SPAT is considered, which needs a 55mm adjustment (see tables on page 19), where the M8 threaded rod starts 20mm above the support plate (INITIAL POSITION).*

55mm ADJUSTMENT

20mm

75mm MEASURE WITH ADJUSTMENT

03. INSTALLATION

ADJUSTMENT TABLES

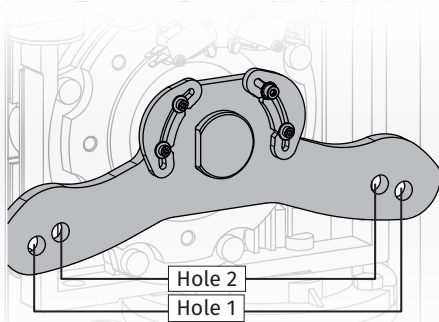

- Depending on the condition of the spring, there may be a tolerance of 5mm in relation to the values indicated in the table.
- You should test the minimum adjustment necessary to compensate the weight of the boom.
- **The values mentioned in the table must be used. If the values are not applied, the guarantee may be cancelled.**



If you want to adjust a ZUMA 6 boom (3400+3400) for measurements up to 4000, you must cut the profiles to the measurements of a ZUMA 4 boom (2400+2400). Only then will you be able to maintain the values in the table.

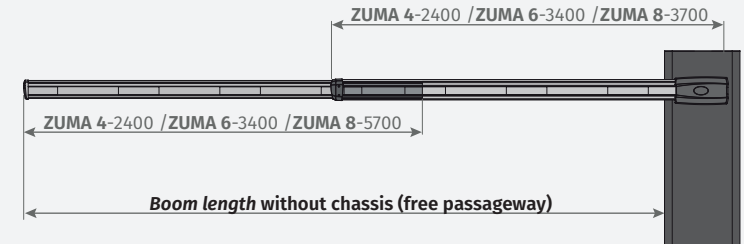

The values in the table refer to booms with LEDs (SIG75HT).
If the boom you want to adjust is without LEDs (ZUM75HTSL), reduce the values in the table by between 10 and 20 mm.

SIMPLE BOOM	ZUMA 4				ZUMA 6				ZUMA 8			
Boom Length	2500	3000	3500	4000	4500	5000	5500	6000	6500	7000	7500	8000
Quantity of springs	1 un.				2 un.				3 un.			
Spring adjustment (mm)	10mm	25mm	50mm	30mm	25mm	10mm	35mm	50mm	10mm	30mm	45mm	55mm
Hole position	Hole 2			Hole 1	Hole 2	Hole 1			Hole 2			
BOOM WITH RUBBER	ZUMA 4				ZUMA 6				ZUMA 8			
Boom Length	2500	3000	3500	4000	4500	5000	5500	6000	6500	7000	7500	8000
Quantity of springs	1 un.				2 un.				3 un.			
Spring adjustment (mm)	7mm	35mm	60mm	50mm	40mm	25mm	45mm	60mm	30mm	45mm	30mm	40mm
Hole position	Hole 2			Hole 1	Hole 2	Hole 1			Hole 2		Hole 1	
BOOM WITH SPAT	ZUMA 4				ZUMA 6				ZUMA 8			
Boom Length	2500	3000	3500	4000	4500	5000	5500	6000	6500	7000	7500	8000
Quantity of springs	1 un.				2 un.				3 un.			
Spring adjustment (mm)	10mm	50mm	70mm	55mm	40mm	25mm	40mm	60mm	30mm	45mm	27mm	35mm
Hole position	Hole 2			Hole 1	Hole 2	Hole 1			Hole 2		Hole 1	
BOOM WITH RUBBER AND SPAT	ZUMA 4				ZUMA 6				ZUMA 8			
Boom Length	2500	3000	3500	4000	4500	5000	5500	6000	6500	7000	7500	8000
Quantity of springs	1 un.				2 un.				3 un.			
Spring adjustment (mm)	20mm	60mm	55mm	70mm	50mm	35mm	55mm	70mm	40mm	60mm	45mm	50mm
Hole position	Hole 2			Hole 1	Hole 2	Hole 1			Hole 2		Hole 1	

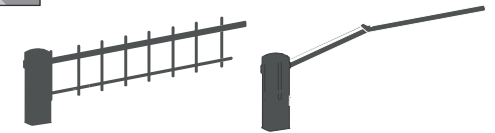

S5	A5 (WITHOUT LEDS)	A5 (WITH LEDS)
5000	5000	5000
2 un.	2 un.	2 un.
65mm	15mm	20mm
Hole 1	Hole 2	Hole 2
S6	A5 (WITHOUT LEDS)	A6 (WITH LEDS)
6000	6000	6000
3 un.	2 un.	2 un.
45mm	15mm	20mm
Hole 2	Hole 2	Hole 2

NOTE: If you want the length of the S5, A5, S6 AND A6 boom to be shorter than the value in the table (original length), you must make the necessary adjustments until the boom reaches the behaviour described on page 20A.

03. INSTALLATION

TEST SPRING ADJUSTMENT

The motor must remain unlocked to carry out the adjustment test.

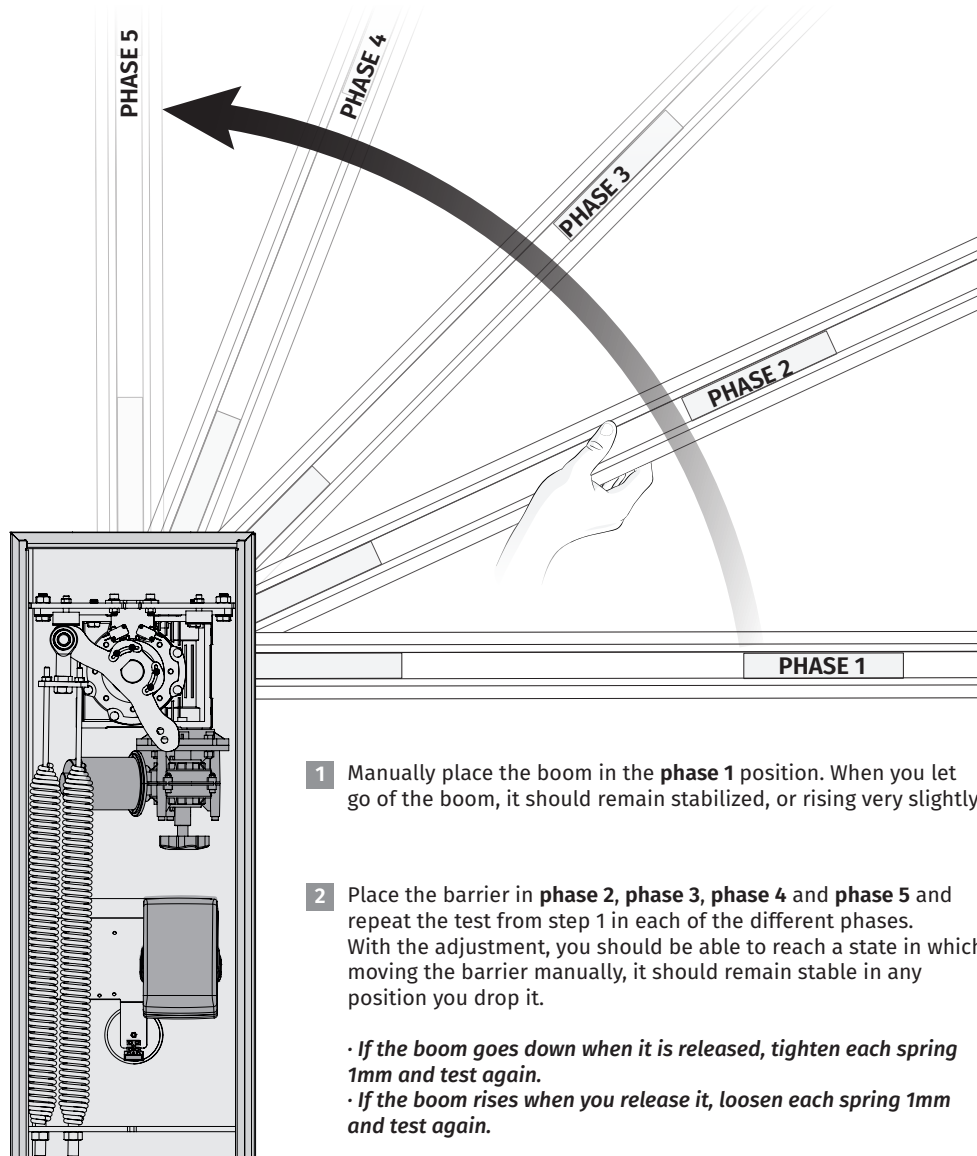

03. INSTALLATION

POWER SUPPLY CABLE

*The power wiring from the ground must be connected directly to the fuse located at the bottom of the barrier.

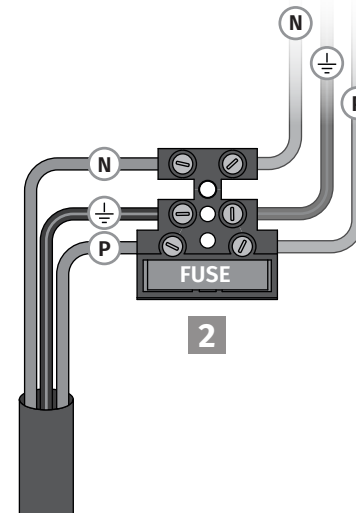
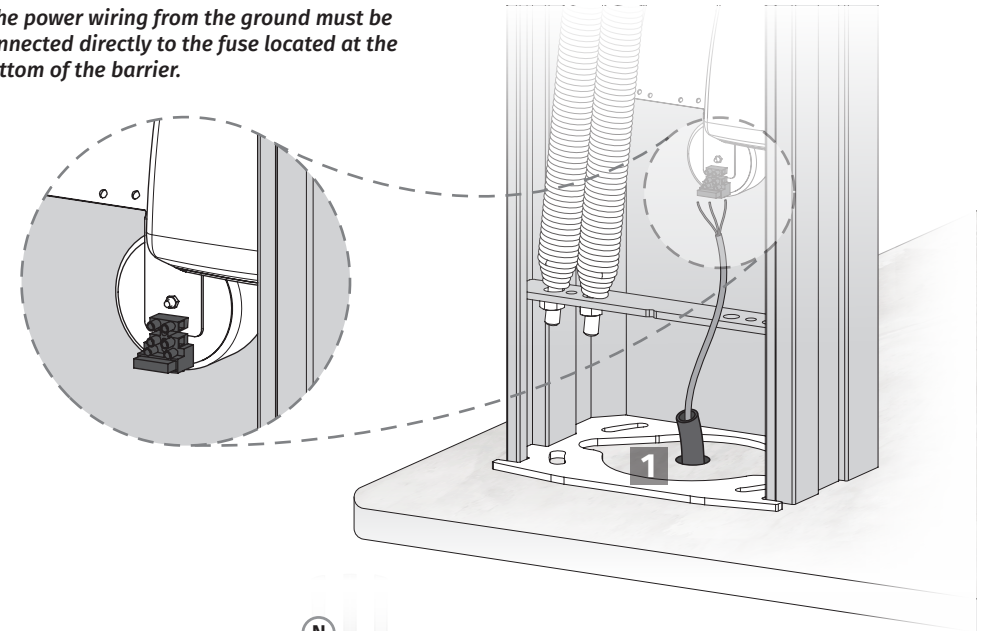

Important: Check the voltage of your transformer before connecting the power supply if it is 230Vac~ or 110Vac~.

See page 22, 23 and 24 for more detailed information

03. INSTALLATION

The stoppers present on the barrier are visible in the image below.

- They consist of 2 adjusting screws (one on each side of the barrier) fixed to the base as well as its 2 stoppers.
- Each screw has a blocking nut.



When the boom opens and closes, the lever must **always touch the rubber stoppers** on the upper barrier plate.

Follow these steps to adjust the position of the stoppers:

- 1 Release the blocking nut from the stopper you want to adjust.
- 2 Place the boom in the desired position:
Horizontal Position - Closing
Vertical Position - Opening
- 3 Turn the stopper on the side you want to adjust until it touches the lever.
- 4 Test boom movement and make final adjustments.
- 5 Re-tighten the blocking nuts to lock the stoppers in that position.

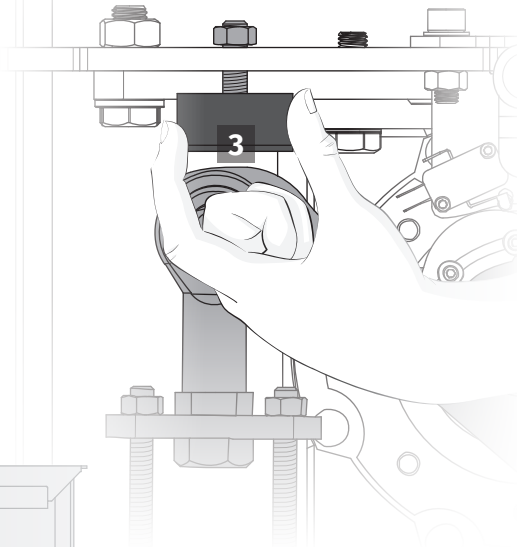
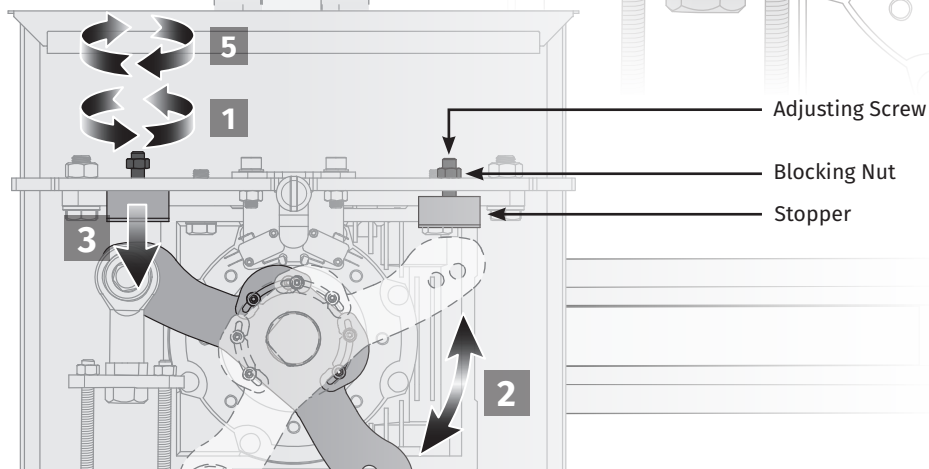

03. INSTALLATION

LIMIT SWITCHES ADJUSTMENT

The ZUMA rotation lever has limit switch micros that allow you to define the end of the opening and closing operations.



These micros **must be set** to be activated the instant before the lever touches the stopper.

Follow these steps to adjust the limit switches:

- 1 Place the boom in a horizontal position.
- 2 Slightly loosen the screws on the activation plate, and move it until you hear the micro activation click.

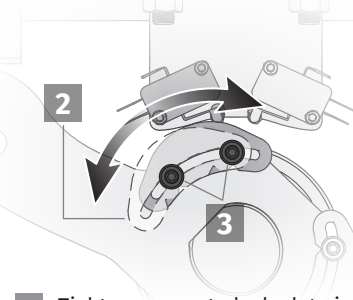

- 3 Tighten screws to lock plate in position.
- 4 Place the boom in the vertical position, and repeat steps 2 and 3 for the other activation plate.

- Place the boom in the horizontal position and check if the control board LED turns off when the plate activates the micro.
- Place the boom in a vertical position and perform the same test.



When the opening or closing micro switch is activated, check if the respective LED on the control board turns off.

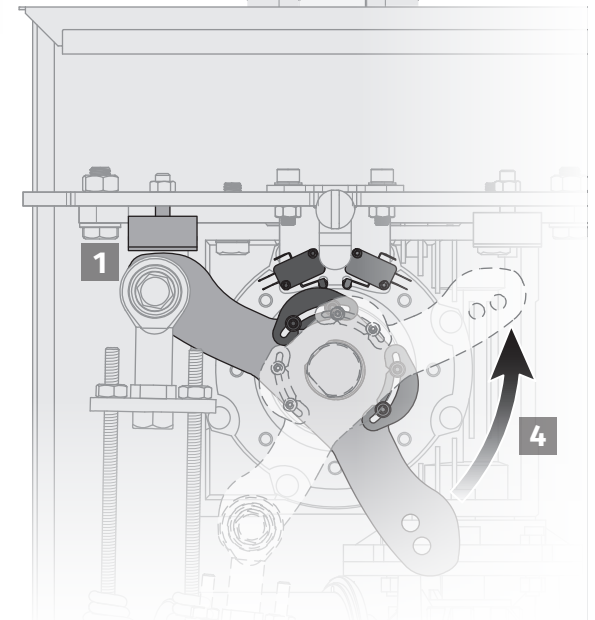
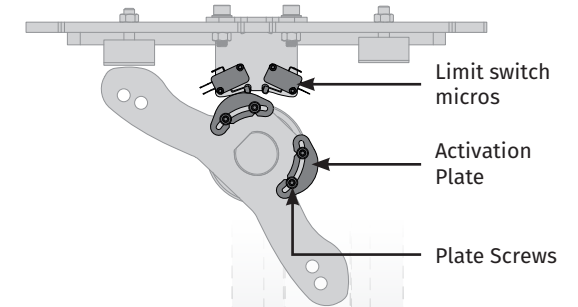

04. CONNECTIONS

CONNECTION SCHEME (ZUMA 4 / ZUMA 6)

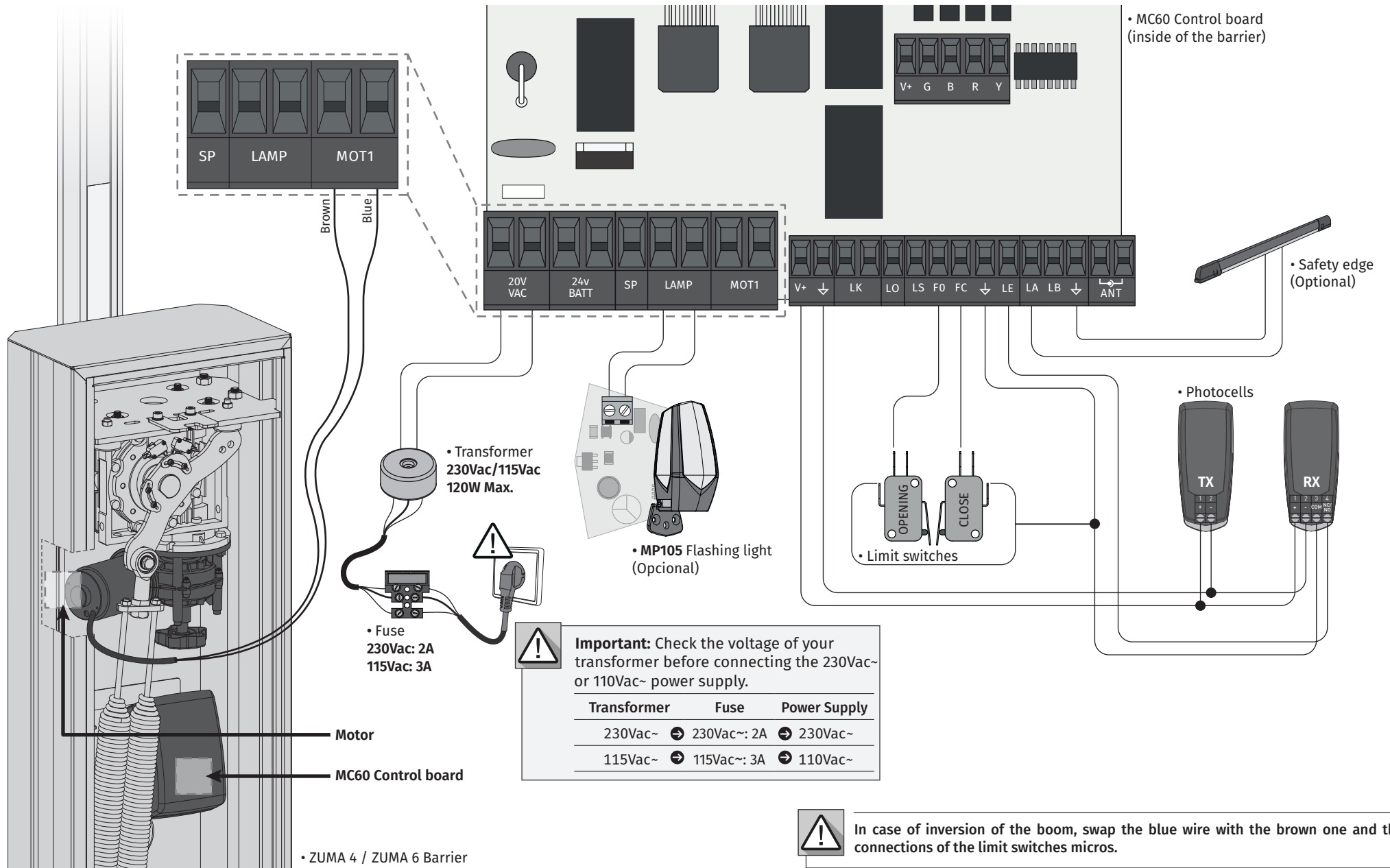

! In case of inversion of the boom, swap the blue wire with the brown one and the connections of the limit switches micros.

04. CONNECTIONS

CONNECTION SCHEME - THTSIG15LEDN MODULE (ZUMA 8)

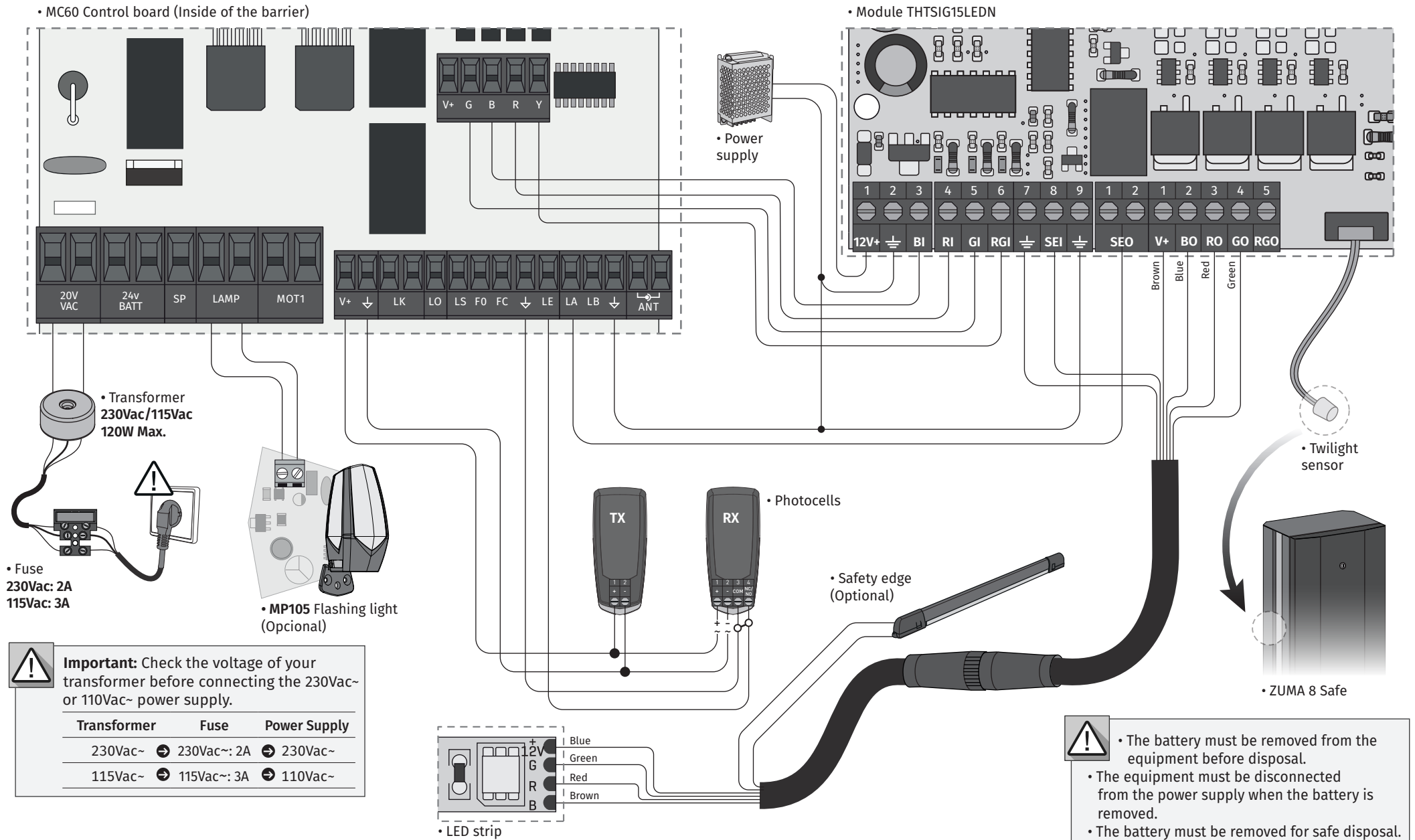

! • The battery must be removed from the equipment before disposal.
 • The equipment must be disconnected from the power supply when the battery is removed.
 • The battery must be removed for safe disposal.

04. CONNECTIONS

CONNECTION SCHEME - MODULE MP106 (ZUMA 8)

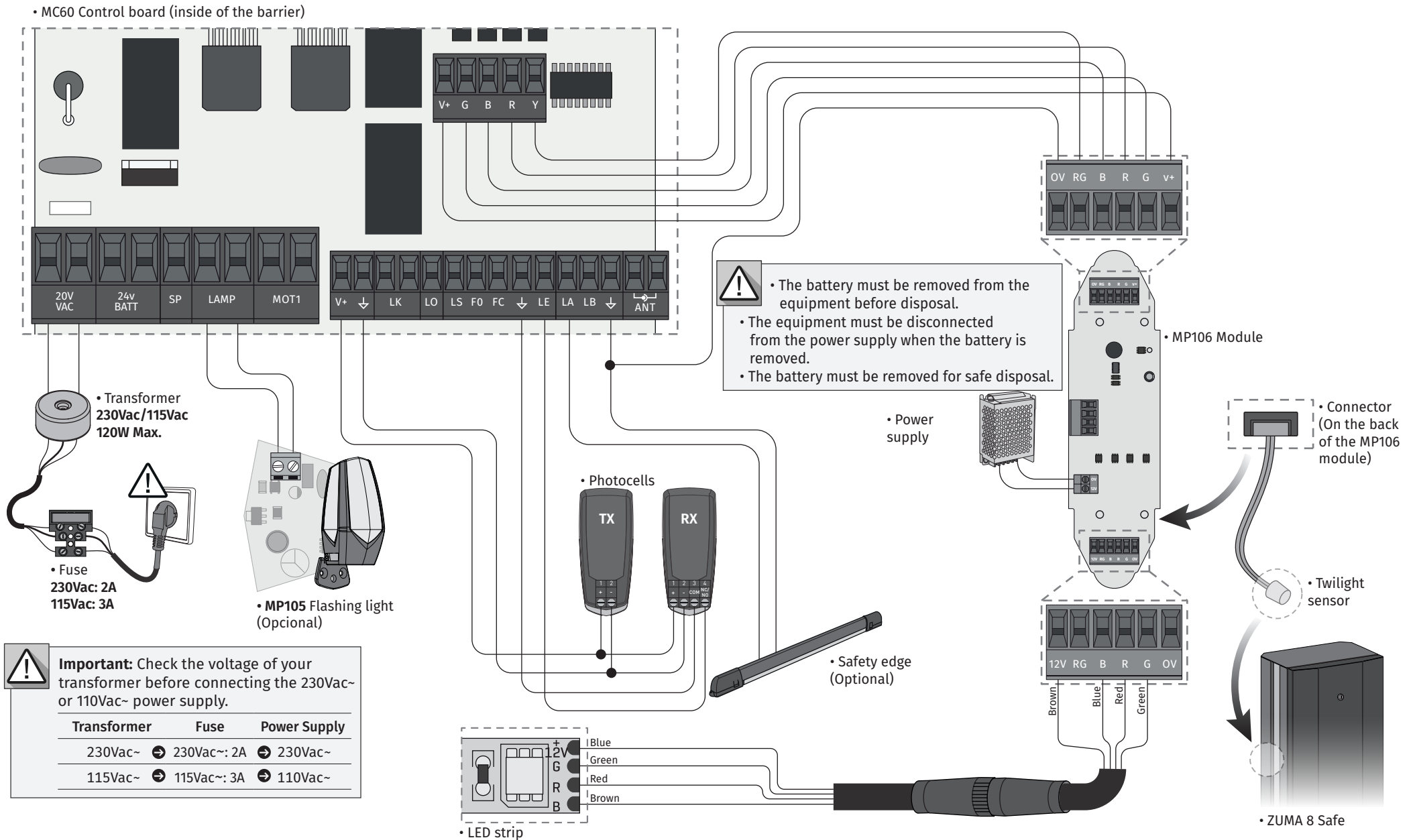

05. TROUBLESHOOTING

INSTRUCTIONS FOR FINAL CONSUMERS / SPECIALIZED TECHNICIANS

Anomaly	Procedure	Behavior	Procedure II	Find out the origin of the problem			
• Barrier doesn't work	• Make sure you have 230V/110V power supply connected to automation and if the fuse working properly.	• Still not working	• Consult a specialized technician.	1 • Remove the frontal door from the barrier; 2 • Measure the 24V output of the transformer to detect the fault location;	A) It has 24V: 1 • Check if the control board is supplying the barrier to detect if the fault is in the motor or control board. Replace damaged component or send to service for	diagnosis and repair. B) Does not has 24V: 1 • Check the 230V input of the transformer. If you have 230V or 110V the problem is with the	transformer. If not, the problem will be in the fuse, electrical cables or the electrical current itself. Check all systems.
	• Check the STOP	• Still not working	• Consult a specialized technician.	1 • Give the order with remote control to open and check the behaviour of the LEDs. 2 • Check the signalling LEDs and	limit switches connections. In case everything is correct and there is no micro activated, the LEDs must be on. Check the entire circuit connecting the	photocells to the barrier. 3 • On E menu, check if STOP is on. If it is enabled and the circuit is not closed, the barrier will not	work. Disable STOP or place a shunt between LA and ↓.
• Barrier does not move but makes noise	• Unlock the barrier and move it manually to check for mechanical problems.	• Is the barrier stuck?	• Consult a technician specialized in barriers.	Check all axes and motion systems associated with the barrier to find out what the	problem is. Also check that the springs are in good condition and can support the barrier.		
		• Does the barrier move easily?	• Consult a specialized technician.	1 • Disconnect the barrier from the control board and test it connected directly to a 12/24 Vdc power supply to find out if it is faulty;	2 • If the barrier works, the problem is with the control board. Remove it and send it to technical services for diagnosis;	3 • If the barrier does not work, remove the motor and send it to technical services for diagnosis.	
• Barrier opens but does not close	1 • Check if there are any obstacles in front of the photocells; 2 • Make sure if the photocells are working. Put your hand in front and check that the relay makes the same noise. 3 • Check if any of the barrier control devices are stuck and sending a permanent signal; 4 • Check the safety edge connections.	• Barrier opened but did not close.	• Consult a specialized technician.	1 • Check that the display is turned on to confirm the existence of power; 2 • Check if the photocells are powered at the control board output; 3 • Access the menu on the display and deactivate the photocells and STOP; 4 • Check limit switch connections. If the 2 signaling LEDs are off, it means that the barrier cannot work, as its limit	switches are activated. 5 • Try to close; A) Closed: 1 • Problem is in one of these two systems. Activate the photocells and check that the barrier closes. If it closes, the problem will be the STOP. Activate it in the menu and try to close the barrier to be sure.	to the barrier to close while measuring the power output from the control board to the motor. If it has 24V, the control board is working and the problem will be in the motor. 2 • If there is no power, the problem is with the control board.	
• Barrier does not make complete route	• Unlock the barrier and move it manually to check for mechanical problems.	• Found problems?	• Consult a technician specialized in barriers.	Check all axes and motion systems associated with the barrier to find out what the	problem is. Also check that the springs are in good condition and can support the barrier.		
		• Does the barrier move easily?	1 • Re-program the limit switches; 2 • Consult a specialized technician.	1 • Check if the barrier tests were done well; 2 • Change the force in P2→FO menu until the barrier moves without inverting direction;	3 • This adjustment must be made in such a way that the barrier, when encountering an obstacle, inverts; 4 • If even at the maximum force level (09) the problem	still persists, test the barrier connected directly to a 12/24 Vdc power supply to verify if it has enough force to open/close the barrier completely; 5 • Change the force in P2→FO	menu until the barrier moves without inverting direction; 6 • In the P2→FS menu, check the sensitivity value (minimum: 00 / maximum: 09) and adjust it to the ideal value to work.