

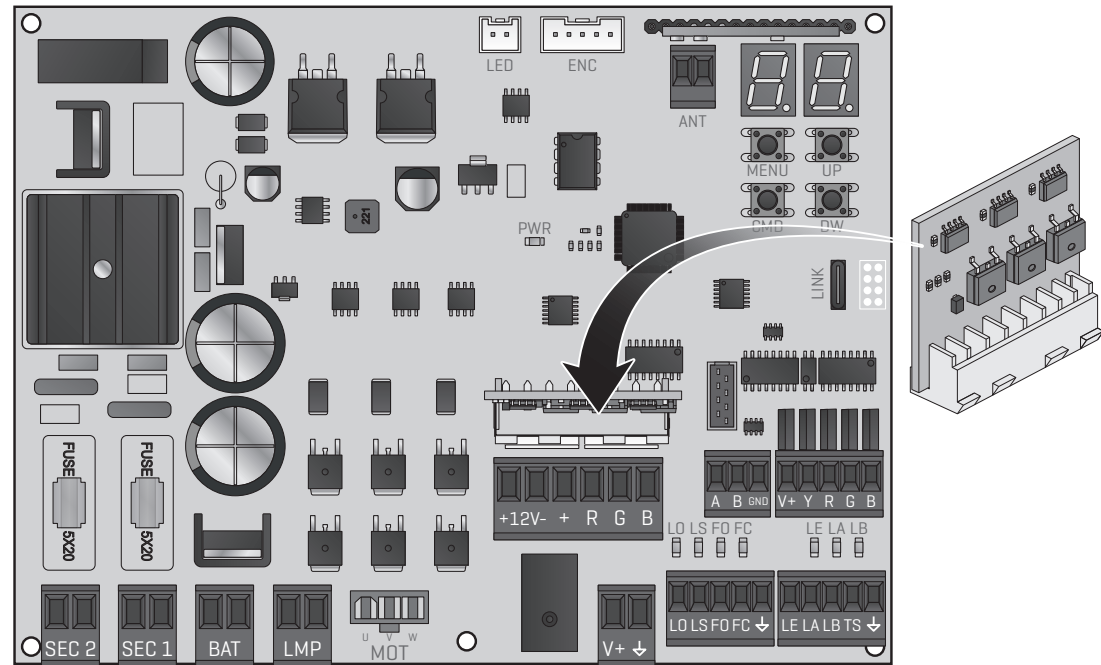

# MC90BL-BR-36V

## USER/INSTALLER MANUAL



# 00. CONTENT

## INDEX

<b>01. SAFETY INSTRUCTIONS</b>	
STANDARDS TO FOLLOW	1B
<b>02. CONTROL BOARD</b>	
TECHNICAL SPECIFICATIONS	4A
CONNECTORS	4B
BUTTONS AND LEDs	5A
<b>03. INSTALLATION</b>	
INSTALLATION OF MCONNECT LINK (OPTIONAL)	5B
ESSENTIAL STEPS FOR INSTALLATION	6A
<b>04. PROGRAMMING</b>	
REMOTE CONTROLS	6B
P MENU FUNCTIONS	7A
PROGRAMMING P	7B
E MENU FUNCTIONS	11A
PROGRAMMING E	11B
<b>05. DISPLAY</b>	
DISPLAY INDICATIONS	15
<b>06. CONNECTION DIAGRAM</b>	
BARRIER	16
MM90-RGB MODULE	17A
MASTER / SLAVE (OPTIONAL)	17B
<b>07. TROUBLESHOOTING</b>	
INSTRUCTIONS FOR FINAL CONSUMERS/TECHNICIANS	18

### Simplified EU Declaration of Conformity







The undersigned **MOTORLINE ELECTROCELOS, S.A., with registered office at Travessa do Sobreiro, n.º 29, 4755-474 Rio Côvo (Santa Eugénia), Barcelos**, declares that the present type of radio equipment - **MC90BL-BR Control board** - ecomplies with the Directive 2014/53/EU.

The full text of the declaration of conformity is available at the following internet address:

<https://motorline.pt/certification/mc90bl>



# 01. SAFETY INSTRUCTIONS

	This product is certified in accordance with European Community (EC) safety standards.
	This product complies with Directive 2011/65/EU of the European Parliament and of the Council, of 8 June 2011, on the restriction of the use of certain hazardous substances in electrical and electronic equipment and with Delegated Directive (EU) 2015/863 from Commission.
	(Applicable in countries with recycling systems). This marking on the product or literature indicates that the product and electronic accessories (eg. Charger, USB cable, electronic material, controls, etc.) should not be disposed of as other household waste at the end of its useful life. To avoid possible harm to the environment or human health resulting from the uncontrolled disposal of waste, separate these items from other types of waste and recycle them responsibly to promote the sustainable reuse of material resources. Home users should contact the dealer where they purchased this product or the National Environment Agency for details on where and how they can take these items for environmentally safe recycling. Business users should contact their vendor and check the terms and conditions of the purchase agreement. This product and its electronic accessories should not be mixed with other commercial waste.
	This marking indicates that batteries should not be discarded like other household waste at the end of their useful life. Batteries must be delivered to selective collection points for recycling.
	The different types of packaging (cardboard, plastic, etc.) must be subject to selective collection for recycling. Separate packaging and recycle it responsibly.
	This marking indicates that the product and electronic accessories (eg. charger, USB cable, electronic material, controls, etc.) are susceptible to electric shock by direct or indirect contact with electricity. Be cautious when handling the product and observe all safety procedures in this manual.

# 01. SAFETY INSTRUCTIONS

## **GENERAL WARNINGS**

- This manual contains very important safety and usage information. Read all instructions carefully before beginning the installation/usage procedures and keep this manual in a safe place that it can be consulted whenever necessary.
- This product is intended for use only as described in this manual. Any other enforcement or operation that is not mentioned is expressly prohibited, as it may damage the product and put people at risk causing serious injuries.
- This manual is intended firstly for specialized technicians, and does not invalidate the user's responsibility to read the "User Norms" section in order to ensure the correct functioning of the product.
- The installation and repair of this product may be done by qualified and specialized technicians, to assure every procedure are carried out in accordance with applicable rules and norms. Nonprofessional and inexperienced users are expressly prohibited of taking any action, unless explicitly requested by specialized technicians to do so.
- Installations must be frequently inspected for unbalance and the wear signals of the cables, springs, hinges, wheels, supports and other mechanical assembly parts.
- Do not use the product if it is necessary repair or adjustment is required.
- When performing maintenance, cleaning and replacement of parts, the product must be disconnected from power supply. Also including any operation that requires opening the product cover.
- The use, cleaning and maintenance of this product may be carried out by any persons aged eight years old and over and persons whose physical, sensorial or mental capacities are lower, or by persons without any knowledge of the product, provided that these are supervision and instructions given by persons with experienced in terms of usage of the product in a safe manner and who understands the risks and dangers involved.

- Children shouldn't play with the product or opening devices to avoid the motorized door or gate from being triggered involuntarily.
- If the power cable is damaged, it must be replaced by the manufacturer, after-sales service or similarly qualified personnel to avoid danger.
- The device must be disconnected from the electrical network when removing the battery.
- Ensure that blocking is avoided between the actuated part and its fixed parts due to the opening movement of the actuated part.

## **WARNINGS FOR TECHNICIANS**

- Before beginning the installation procedures, make sure that you have all the devices and materials necessary to complete the installation of the product.
- You should note your Protection Index (IP) and operating temperature to ensure that is suitable for the installation site.
- Provide the manual of the product to the user and let them know how to handle it in an emergency.
- If the automatism is installed on a gate with a pedestrian door, a door locking mechanism must be installed while the gate is in motion.
- Do not install the product "upside down" or supported by elements do not support its weight. If necessary, add brackets at strategic points to ensure the safety of the automatism.
- Do not install the product in explosive site.
- Safety devices must protect the possible crushing, cutting, transport and danger areas of the motorized door or gate.
- Verify that the elements to be automated (gates, door, windows, blinds, etc.) are in perfect function, aligned and level. Also verify if the necessary mechanical stops are in the appropriate places.
- The control board must be installed on a safe place of any fluid (rain, moisture, etc.), dust and pests.
- You must route the various electrical cables through protective tubes, to protect them against mechanical exertions, essentially on

# 01. SAFETY INSTRUCTIONS

the power supply cable. Please note that all the cables must enter the control board from the bottom.

- If the automatism is to be installed at a height of more than 2,5m from the ground or other level of access, the minimum safety and health requirements for the use of work equipment workers at the work of Directive 2009/104/CE of European Parliament and of the Council of 16 September 2009.
- Attach the permanent label for the manual release as close as possible to the release mechanism.
- Disconnect means, such as a switch or circuit breaker on the electrical panel, must be provided on the product's fixed power supply leads in accordance with the installation rules.
- If the product to be installed requires power supply of 230Vac or 110Vac, ensure that connection is to an electrical panel with ground connection.
- The product is only powered by low voltage safety with control board (only at 24V motors).
- Parts/products weighing more than 20 kg must be handled with special care due to the risk of injury. It is recommended to use suitable auxiliary systems for moving or lifting heavy objects.
- Pay special attention to the danger of falling objects or uncontrolled movement of doors/gates during the installation or operation of this product.

## WARNINGS FOR USERS

- Keep this manual in a safe place to be consulted whenever necessary.
- If the product has contact with fluids without being prepared, it must immediately disconnect from the power supply to avoid short circuits, and consult a specialized technician.
- Ensure that technician has provided you the product manual and informed you how to handle the product in an emergency.
- If the system requires any repair or modification, unlock the automatism, turn off the power and do not use it until all safety

conditions have been met.

- In the event of tripping of circuits breakers or fuse failure, locate the malfunction and solve it before resetting the circuit breaker or replacing the fuse. If the malfunction is not repairable by consult this manual, contact a technician.
- Keep the operation area of the motorized gate free while the gate in in motion, and do not create strength to the gate movement.
- Do not perform any operation on mechanical elements or hinges if the product is in motion.

## RESPONSABILITY

- Supplier disclaims any liability if:
  - Product failure or deformation result from improper installation use or maintenance!
  - Safety norms are not followed in the installation, use and maintenance of the product.
  - Instructions in this manual are not followed.
  - Damaged is caused by unauthorized modifications
  - In these cases, the warranty is voided.

## **MOTORLINE ELECTROCELOS SA.**

Travessa do Sobreiro, nº29  
4755-474 Rio Côvo (Santa Eugénia)  
Barcelos, Portugal

## SYMBOLS LEGEND:



• Important safety notices



• Useful information



• Programming information



• Potentiometer information



• Connectors information



• Buttons information

## 02. CONTROL BOARD

### TECHNICAL SPECIFICATIONS

The MC90BL-BR is an electronic control board for controlling brushless motors with a built-in radio control system, developed for automating barriers.

<b>B</b>	• Motor power supply	26Vac
<b>A</b>	• Control board power supply	21 Vac
<b>D</b>	• Flashing light's output	36Vdc 4W Max.
<b>K</b>	• RGB Flashing light's output	24Vdc 100mA Max.
<b>E</b>	• Motor's output	36Vdc 300W Max.
<b>F</b>	• Auxiliary accessories output	24Vdc 8 W Max.
<b>G/H</b>	• Security device output and push button	24Vdc
	• Working temperature	-25°C to + 55°C
<b>L</b>	• Incorporated Radio Receiver	433,92 Mhz
	• Compatible remote controls	12bits or Rolling Code
<b>M</b>	• Maximum Memory Capacity	100 (full opening) - 100 (pedestrian opening)
	• Control Board Dimensions	159x119 mm
	• Fuse F1   Fuse F2	8AL 250V   1.6AL 250V
<b>C</b>	• Battery	24Vdc 7A

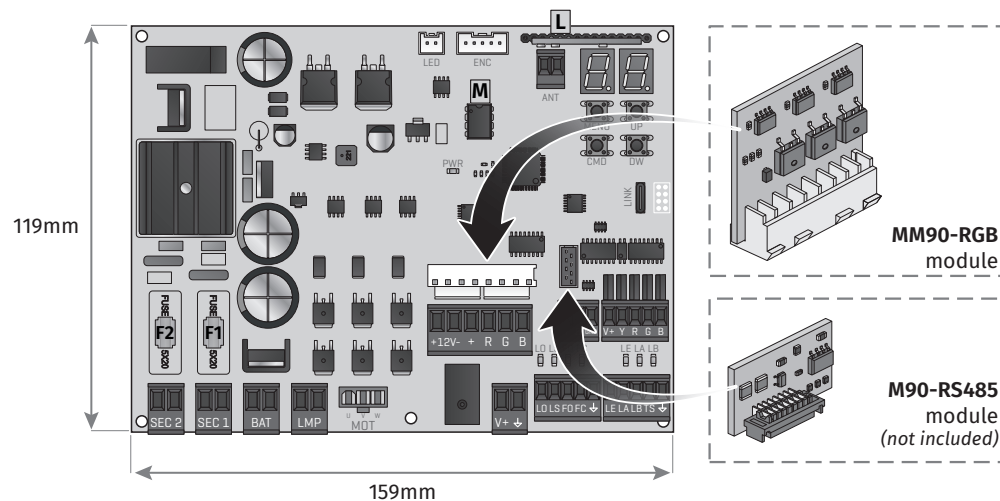

## 02. CONTROL BOARD

### CONNECTORS

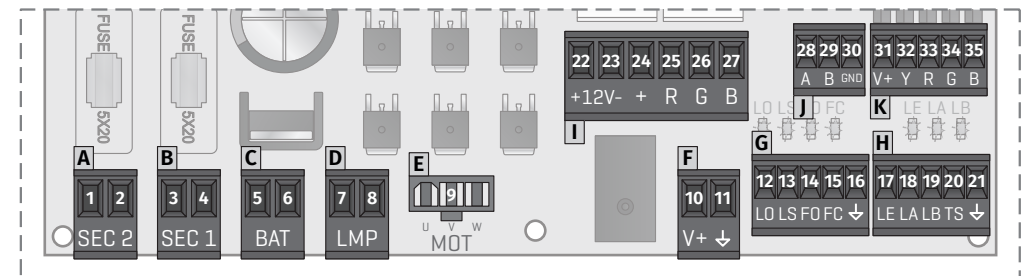

<b>A</b>	SEC2	01 • 21Vac control board power input 02 • 21Vac control board power input	
<b>B</b>	SEC1	03 • 20Vac motor power input 04 • 20Vac motor power input	
<b>C</b>	BAT	05 • 24Vdc Input for Emergency Battery 24V + max 7Ah 06 • 24Vdc Input for Emergency Battery 24V - max 7Ah	
<b>D</b>	LMP	07 • 36Vdc Flashing light's Output (max 4W) 08 • 0V Flashing light's Output	
<b>E</b>	MOT	09 • 36Vdc Motor Output (max 300W)	
<b>F</b>	V+ ↓	10 • 24Vdc output for accessories (max 8W) 11 • 0V output for accessories power supply	
<b>G</b>	LO LS FO FC ↓	12 • NO input for Total Opening Input 13 • NO input for Partial maneuver button 14 • Opening limit-switch input 15 • Closing limit-switch input 16 • Common	
<b>H</b>	LE LA LB TS ↓	17 • NC input for Photocells 1 18 • NC input for Photocells 2 19 • NC input for Stop device 20 • Photocell test output 21 • Common	
<b>I</b>	LED	22 • +12Vdc input for powering the RGB strip on the boom 23 • 0Vdc input for powering the RGB strip on the boom 24 • +12Vdc output for RGB strip 25 • RGB output - Red 26 • RGB output - Green 27 • RGB output - Blue	This connector only works if you apply the MM90-RGB module
<b>J</b>	RS485	28 • Signal A   29 • Signal B   30 • GND	
<b>K</b>	V+ Y R G B	31 • Common Output +24vdc (max 4W) 32 • Output for Closed Barrier signal 33 • Output for barrier signal to close 34 • Output for barrier signal to open 35 • Output for Open Barrier signal	

## 02. CONTROL BOARD

### CONNECTORS

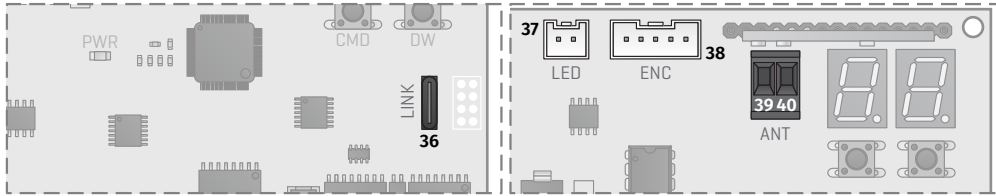

LINK	36 • Type-C input for MCONNECT LINK connection
LED	37 • Connector for flashing light RGB
ENC	38 • Connector for motor encoder
ANT	39 • Antenna connector (hot pole) 40 • Antenna connector (GND)

### BUTTONS AND LEDs



MENU	Access the Menu
CMD	Remote controls programming
UP	Navigate through menus/values
DW	Navigate through menus/values



LO	LED ON when the full opening button is active
LS	LED ON when the pedestrian opening button is active
FO	LED OFF when the opening limit switch is active
FC	LED OFF when closing limit switch is active
LE	LED OFF when the signal from the photocells 1 is interrupted
LA	LED OFF when the signal from the photocells 2 is interrupted
LB	LED OFF when the Stop button is active
PWR	LED ON when power is supplied to the microcontroller

## 03. INSTALLATION

### INSTALLATION OF MCONNECT LINK (OPTIONAL)

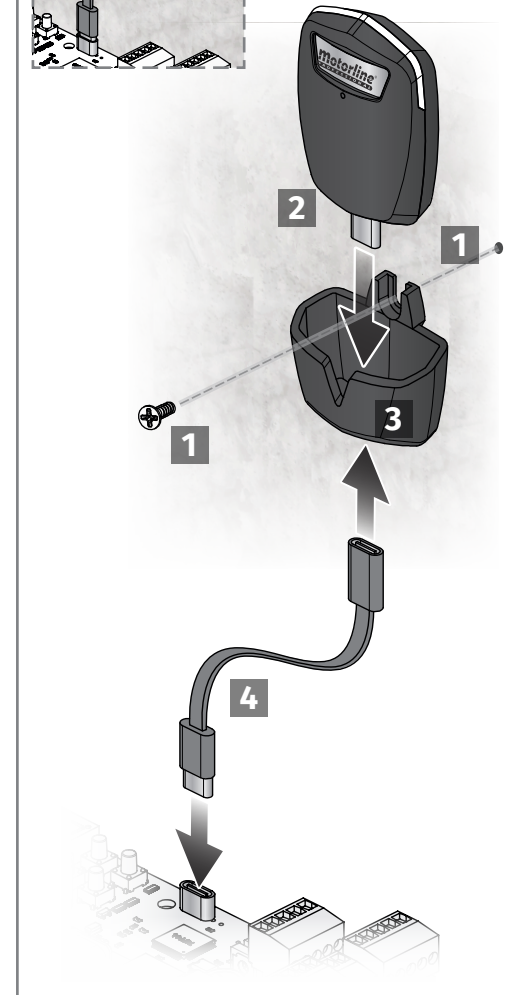
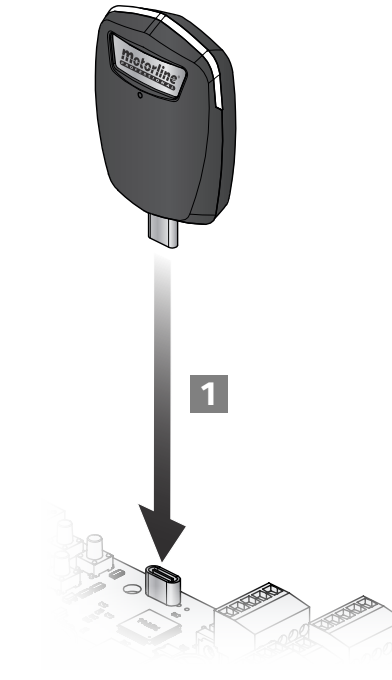
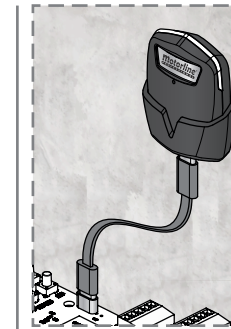
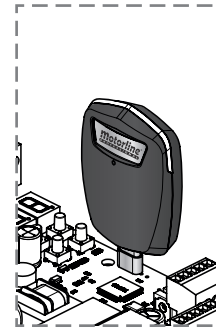

## 03. INSTALLATION

### ESSENTIAL STEPS FOR INSTALLATION

- 01 • Make the connections of all the accessories according to the connection scheme (page 15 and 16).
- 02 • Connect the transformer to a power supply.
- 03 • Make sure that the barrier movement is the same as the one shown on the display:

00	00	 If the display does not coincide with the movement of the barrier, change the opening direction parameter in P0->d1 to 1.
CLOSING	OPENING	

- 04 • Automatically program the course - **P0** menu (page 7B).
- 05 • If necessary, adjust the barrier slowdown time during opening and closing - **P1** menu (page 8A).
- 06 • Adjust the speed and sensitivity of the motor - **P2** menu (page 8A).
- 07 • Enable or disable the use of photocells in the **P5** menu (page 9A).
- 08 • Program a remote control (page 6B).

The control board is now fully configured!

Check the menus from the programming pages in case you wish to configure other features of the control board.

**NOTE:** Whenever the barrier door is opened, the first manoeuvre performed is calibration. To signal that the barrier needs to be calibrated, the flashing light will turn blue.



When the access door to the barrier mechanics is open, the control board is in security mode and does not accept opening orders. To signal that the door is open, the flashing light flashes red.

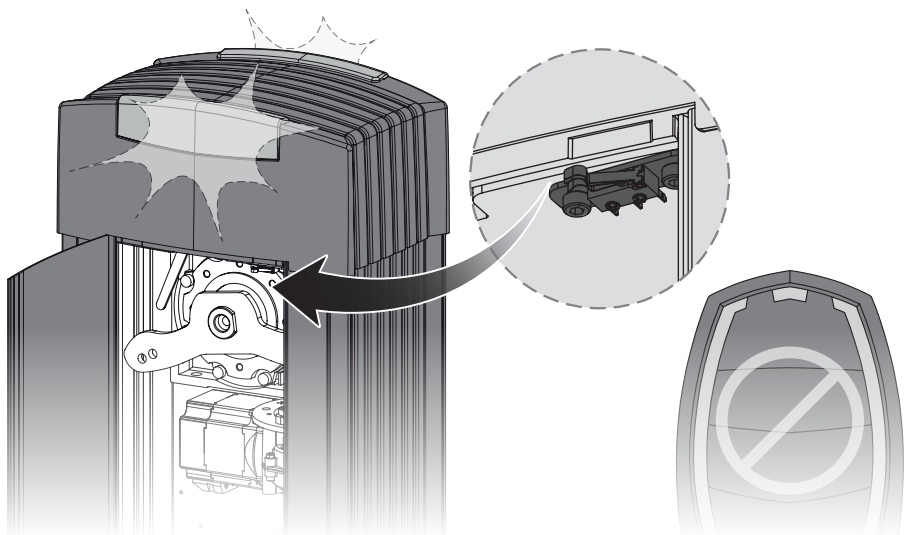

## 04. PROGRAMMING

### REMOTE CONTROLS

SU	Programming a remote control for full opening		88
SP	Programming a remote control for pedestrian opening		88
SR	Function of programmed remote controls in SP	00	Remote control for pedestrian opening.
	Allows to configurate the pedestrian opening remote control for total opening.	01	Remote control for total opening.
			00 (Default value)

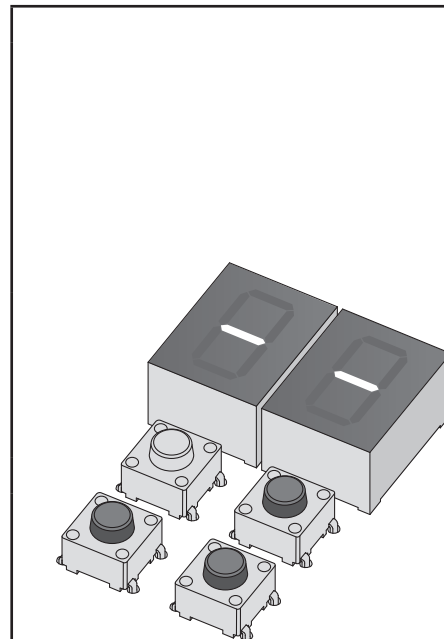

#### REMOTE CONTROL PROGRAMMING

- 01 • Press the **cmd** button for 1 sec.
- 02 • Select the function where you want to program the remote controls (SU and SP) using ↓↑.
- 03 • Press **cmd** once to confirm the function (SU or SP).
- 04 • The first free position appears.
- 05 • Press the remote control button you want to program. The display will blink and move to the next free location.

#### PROGRAM SL FUNCTION

- 01 • Press the **cmd** button for 1 sec.
- 02 • Select the SL function using ↓↑.
- 03 • Press **cmd** to enter the function.
- 04 • Use ↓↑ to change the value.
- 05 • Press **MENU** to save the new value.

#### DELETE REMOTE CONTROLS

- 01 • Press the **cmd** button for 1 sec.
- 02 • Select the function (SU or SP) using ↓↑.
- 03 • Press **cmd** once to confirm the function (SU or SP).
- 04 • Use ↓↑ to select the remote control location you want to delete.
- 05 • Press **cmd** for 3sec. and the position is empty. The display will flash and the position will be available.

#### DELETE ALL THE REMOTE CONTROLS

- 01 • Press the **cmd** button for 5 sec.
- 02 • The display will show **dL**, confirming that all remote controls have been deleted.



- Whenever you store or delete a remote control, the display will flash and show the next position. You can add or delete remote controls without go back to point 01.
- If you do not press any button for 20 seconds the control board will return to standby.

# 04. PROGRAMMING

## "P" MENU FUNCTIONS



MENU	FUNCTION	MIN.	MAX.	STATE	FACTORY VALUE	PAGE
80	COURSE PROGRAMMING	-	-	RU Automatic Programming	-	7B
				RS 00 Master 01 Slave	00	
				RL 00 Left opening 01 Right opening	00	8A
				RR Boom size selection	07	
		0	7	SR Solar mode	00	
81	SLOWDOWN ADJUSTMENT	0%	99%	SR Opening slowdown	20%	8B
				SR Closing slowdown	22%	
				RE Ramp time at start RE Ramp time in slowdown	02 03	
82	SPEED AND SENSITIVITY ADJUSTMENT	0	9	SE Opening speed adjustment	02	8B
				SE Closing speed adjustment	01	
				ES Sensitivity adjustment	02	
83	PEDESTRIAN COURSE ADJUSTMENT	0%	99%	Opening setting in pedestrian mode	0%	9A
84	PAUSE TIME	0s	99s	RE Total pause time adjustment	5s	9A
				RE Pedestrian pause time adjustment	0s	
85	PHOTOCELLS 1 PROGRAMMING	-	-	EE 00 Disables photocells 01 Active photocells	00	9B
				HE 00 Photocells in opening 01 Photocells in closing	01	
				HE 00 Invert 01 Stop 02 Invert 2 sec. and Stop	00	
				SE 00 Disable photocell test 01 Activates photocell test	00	
86	PHOTOCELLS 2 PROGRAMMING	-	-	ER 00 Disables photocells 01 Active photocells	00	10A
				HE 00 Photocells in opening 01 Photocells in closing	00	
				HE 00 Invert 01 Stop 02 Invert 2 sec. and Stop	01	
				RR 00 Disables safety edge input 01 Activates safety edge input	00	
				SE 00 Disable photocell test 01 Activates photocell test	00	

# 04. PROGRAMMING

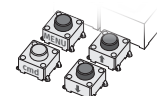
## "P" MENU FUNCTIONS

88	OPERATING LOGIC	-	-	00 Automatic mode 01 Step by step mode 02 Condominium mode	02	10B
88	FLASHING LIGHT	-	-	00 Flashing (opening and closing) 01 During movement 02 Courtesy light	00	10B
89	REMOTE PROGRAMMING	-	-	00 Remote programming OFF 01 Remote programming ON	00	11A
				<ul style="list-style-type: none"> <li>To access the <b>P menu</b> press the MENU button for 2 seconds.</li> <li>Use ↓ ↑ to navigate through the menus.</li> <li>Press MENU when you want to confirm access to a menu.</li> <li>Press ↓ ↑ simultaneously to exit programming.</li> </ul>		

## PROGRAMMING "P"

P0 COURSE PROGRAMMING		
RU	<b>Automatic course programming</b>	This menu allows you to automatic programming of the motor and slowdown.
<b>Automatic programming:</b> 01 • Press MENU for 2 sec. until it appears P0. 02 • Press MENU once until it appears RU. 03 • Press MENU to start automatic programming.		
The following maneuvers will be carried out: <b>a</b> • Closes in slowdown (if it's open). <b>b</b> • Opens in slowdown. <b>c</b> • Closes in slowdown. <b>d</b> • Opens at normal speed. <b>e</b> • Closes at normal speed.		
 <b>To cancel the programming press the UP and DOWN buttons simultaneously. You can use the remote control instead of the MENU button.</b>		
RS	<b>Master/Slave</b> Communication model for hardware devices where one device has one-way control over another device.  To activate this parameter it is necessary to apply the MM90-RS485 module.	<b>00 Master</b> Controls the main functions of the Slave.
	<b>01 Slave</b> It is controlled by the Master.	<b>00</b> (Default value)

## 04. PROGRAMMING



### PROGRAMMING "P"

<b>00</b>	<b>Opening direction</b> Allows you to define the opening direction of the barrier.	<b>00</b> Left opening	<b>00</b> (Default value)
		<b>01</b> Right opening	
<b>07</b>	<b>07</b> <b>Boom size selection</b> Allows you to configure the barrier speeds according to the selected boom size.	<b>00</b> Boom up to 2.5m	<b>07</b> (Default value)
		<b>01</b> Boom up to 3m	
		<b>02</b> Boom up to 3.5m	
		<b>03</b> Boom up to 4m	
		<b>04</b> Boom up to 4.5m	
		<b>05</b> Boom up to 5m	
		<b>06</b> Boom up to 5.5m	
		<b>07</b> Boom up to 6m	
<b>00</b>	<b>Solar mode</b> This menu allows you to shorten the start-up time of the control centre.  For installations with the APOLO system.	<b>00</b> Disable Solar Mode	<b>00</b> (Default value)
		<b>01</b> Activate Solar Mode	

01 • Press MENU for 2 sec. until it appears **00**.  
02 • Press MENU once until it appears **07**. Use UP or DW to navigate the parameters.  
03 • Press MENU to select the chosen parameter.  
04 • The factory set value appears. Use UP and DW to change the value.  
05 • Press MENU to save the new value.

## 04. PROGRAMMING

### PROGRAMMING "P"

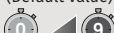
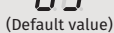
<b>P1 SLOWDOWN ADJUSTMENT</b> This menu allows to set the slowdown time at opening and closing.		
<b>00</b>	<b>Opening slowdown</b> Allows to set the time that the barrier will act with slowdown in the opening (100% corresponds to full opening). 0=OFF	<b>20%</b> (Default value) 
<b>00</b>	<b>Closing slowdown</b> Allows to set the time that the barrier will act with slowdown in the closing (100% corresponds to total closing). 0=OFF	<b>22%</b> (Default value) 
<b>00</b>	<b>Ramp time at start</b> Allows you to define the acceleration ramp time when opening and closing.	<b>02</b> (Default value)  0=OFF   1=0,2   5=1,1   9=2
<b>00</b>	<b>Ramp time in slowdown</b> Allows you to define the deceleration ramp time when opening and closing.	<b>03</b> (Default value)  0=OFF   1=0,2   5=1,1   9=2

01 • Press MENU for 2 sec. until appears **P0**.  
02 • Use UP to change to **P1**.  
03 • Press MENU until appears **00**. Use UP or DW to navigate the parameters.  
04 • Press MENU to edit the chosen parameter value.  
05 • The factory set time appears. Use UP and DW to change the value.  
06 • Press MENU to save the new value.

<b>P2 SPEED AND SENSITIVITY ADJUSTMENT</b>		
<b>00</b>	<b>Opening speed adjustment</b>	<b>02</b>
<b>00</b>	<b>Closing speed adjustment</b>	<b>00</b>
<b>00</b>	<b>Sensitivity adjustment</b> Allows to adjust the sensitivity of the motor when detecting obstacles. The higher the sensitivity, the less effort it will take to detect any obstacle and reverse direction.	<b>02</b> (Default value) 

01 • Press MENU for 2 sec. until appears **P0**.  
02 • Use UP until appears **P2**.  
03 • Press MENU will appear **00**. Use UP or DW to navigate the parameters.  
04 • Press MENU to edit the value.  
05 • The factory set time appears. Use UP and DW to change the value.  
06 • Press MENU to save the new value.



A very low value in the **00** or **00**, parameters, or a very high value in the **00**, parameter, can cause the motor to not have enough torque to move the boom.

## 04. PROGRAMMING

### PROGRAMMING "P"

<b>P3 PARTIAL COURSE ADJUSTMENT</b> Partial mode allows the barrier to be opened to allow people to pass through. In this function you can define the percentage of course that you want the barrier to open in partial mode, in relation to the total course (100%).	
01 • Press MENU for 2 sec. until appears <b>P0</b> . 02 • Use UP until appears <b>P3</b> . 03 • Press MENU. The factory set time appears. 04 • Use UP and DW to change the value. 05 • Press MENU to save the new value.	

<b>P4 PAUSE TIME</b>	
<b>AE Pause time adjustment for automatic closing</b> Allows you to set the waiting time for the barrier from when it finishes fully opening until it starts to close.	
<b>AP Adjustment of pause time for automatic closing in partial closing</b> Allows you to define the waiting time from when partial opening ends until closing begins.	
01 • Press MENU for 2 sec. until appears <b>P0</b> . 02 • Use UP to change to <b>P4</b> . 03 • Press MENU until appears <b>AE</b> . Use UP or DW to navigate the parameters. 04 • Press MENU to edit the chosen parameter value. 05 • The factory set time appears. Use UP and DW to change the value. 06 • Press MENU to save the new value.	

<ul style="list-style-type: none"> <li>• When the values are at zero, there is no automatic closing.</li> <li>• Each value (1s) selected above 90s is equivalent to 20 seconds.  <b>Example:</b> Selecting the value <b>92s</b> is equivalent to 130 seconds (<b>90 + (2 x 20)</b> seconds)</li> </ul>
------------------------------------------------------------------------------------------------------------------------------------------------------------------------------------------------------------------------------------------------------------------------------------------------------------

## 04. PROGRAMMING

### PROGRAMMING "P"

<b>P5 PHOTOCELLS 1 PROGRAMMING</b> Allows to program the security behavior LE (photocell 1).		
<b>LE</b> Enable or disable security entry.	<b>00</b> Disable photocells	
	<b>01</b> Activate photocells	
<b>HE</b> Allows you to define whether this security will act on the opening or closing of the barrier. <i>This menu can only be changed when the LE menu is active.</i>	<b>00</b> Photocells in opening	
	<b>01</b> Photocells in closing	
<b>HE</b> It allows to define the behavior that the barrier will have when this security is activated.	<b>00</b> The barrier movement is reversed	
	<b>01</b> The barrier stops and resumes 5 sec after security is disabled	
	<b>02</b> The barrier reverses for 2 sec. and stop	
<b>SE Photocell Test</b> Before each boom movement, the control board tests whether the photocells are working correctly, reducing the risk of accidents if they fail.	<b>00</b> Disable photocell test	
	<b>01</b> Activates photocell test	
01 • Press MENU for 2 sec. until appears <b>P0</b> . 02 • Use UP until appears <b>P5</b> . 03 • Press MENU will appear <b>LE</b> . Use UP or DW to navigate the parameters. 04 • Press MENU to edit the chosen parameter value. 05 • The factory set time appears. Use UP and DW to change the value. 06 • Press MENU to save the new value.		

## 04. PROGRAMMING

### PROGRAMMING "P"

<b>P6 PHOTOCELLS 2 PROGRAMMING</b> Allows to program the security behavior LA (photocell 2).		
<b>LA</b> Enable or disable security entry.	00 Disable photocells	00 (Default value)
	01 Activate photocells	
Allows you to define whether this security will act on the opening or closing of the barrier. <b>This menu can only be changed when the LA menu is active.</b>	00 Photocells in opening	00 (Default value)
	01 Photocells in closing	
It allows to define the behavior that the barrier will have when this security is activated.	00 The barrier movement is reversed	01 (Default value)
	01 The barrier stops and resumes 5 sec after security is disabled	
	02 The barrier reverses for 2 sec. and stop	
Allows you to activate or deactivate the safety edge.	00 Disables 8k2 safety edge	00 (Default value)
	01 Activates 8k2 safety edge	
<b>Photocell Test</b> Before each boom movement, the control board tests whether the photocells are working correctly, reducing the risk of accidents if they fail.	00 Disable photocell test	00 (Default value)
	01 Activates photocell test	
01 • Press MENU for 2 sec. until appears <b>P0</b> . 02 • Use UP to change to <b>P6</b> . 03 • Press MENU until appears <b>LA</b> . Use UP or DW to navigate the parameters. 04 • Press MENU to edit the chosen parameter value. 05 • The factory set time appears. Use UP and DW to change the value. 06 • Press MENU to save the new value.		

## 04. PROGRAMMING

### PROGRAMMING "P"

<b>P7 OPERATING LOGIC</b> This menu allows to set the operating logic of the automation.		
00 <b>Automatic Mode</b> Whenever there is an order the movement is reversed.		02 (Default value)
<b>Step by step mode</b> 1st impulse: <b>OPEN</b> 2nd impulse: <b>STOP</b> 3rd impulse: <b>CLOSE</b> 4th impulse: <b>STOP</b> If it is fully open and timed, it closes.	01	
<b>02 Condominium Mode</b> Does not respond to orders during opening and pause time.		
01 • Press MENU for 2 sec. until appears <b>P0</b> . 02 • Use UP until appears <b>P7</b> . 03 • Press MENU will appear <b>00</b> . 04 • Press MENU to edit the value. 05 • Use UP and DW to change the value. 06 • Press MENU to save the new value.		
<b>P8 FLASHING LIGHT</b> This menu allows to set the operation mode of the flashing light (LAMP).		
<b>00 Flashing (opening and closing)</b> During the opening/closing movement, the flashing light will operate intermittently. <b>Opening:</b> flashing 0,5sec.   <b>Closing:</b> flashing 0,25sec.		00 (Default value)
<b>01 During movement</b> During the opening/closing movement, the flashing light is permanently ON. <b>When stopped:</b> it remains off.	01	
<b>02 Courtesy light</b> During the opening/closing movement, the flashing light is permanently ON. <b>When in pause time:</b> it remains ON. <b>When stopped or closed:</b> it remains on for the time set in <b>E2</b> .	02	
01 • Press MENU for 2 sec. until appears <b>P0</b> . 02 • Use UP until appears <b>P8</b> . 03 • Press MENU will appear <b>00</b> . 04 • Press MENU to edit the value. 05 • Use UP and DW to change the value. 06 • Press MENU to save the new value.		

# 04. PROGRAMMING

## PROGRAMMING "P"

<b>REMOTE PROGRAMMING</b> <i>P9</i> This menu allows to enable or disable the programming of new remote control without directly accessing the control board, using a previously stored remote control (memorize remote controls page 6A).	
<i>00</i> <b>REMOTE PROGRAMMING OFF</b>	<i>00</i> (Default value)
<i>01</i> <b>REMOTE PROGRAMMING ON</b>	
<p>01 • Press MENU for 2 sec. until appears <i>P0</i>.          02 • Use UP until appears <i>P9</i>.          03 • Press MENU will appear <i>00</i>.          04 • Press MENU to edit the value.          05 • Use UP and DW to change the value.          06 • Press MENU to save the new value.</p>	
<b>REMOTE PROGRAMMING OPERATION (PGM ON):</b> Press the buttons indicated in the image simultaneously for 10 seconds and the flashing light will flash (the 1st free position appears in the display). Each time you store 1 remote control, the control board will exit remote programming. If you want to memorize more remote control, you will always have to repeat the process of pressing the remote controls buttons simultaneously for 10 seconds for each new remote control.	

# 04. PROGRAMMING

## "E" MENU FUNCTIONS

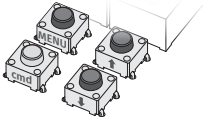
MENU	FUNCTION	MIN.	MAX.	STATE	FACTORY VALUE	PAGE	
<i>E0</i>	HUMAN PRESENCE	-	-	<i>HP</i> <i>00</i> Disables Human presence <i>01</i> Active at closing <i>02</i> Active during opening and closing	00	11B	
				<i>PR</i> <i>00</i> Disables push buttons mode <i>01</i> Activates push buttons mode			00
				<i>LB</i> <i>00</i> Disables LB input (STOP) <i>01</i> Activates LB input (STOP)			
<i>E1</i>	CALIBRATION	1	9	Allows you to calibrate the barrier's course with the encoder.	01	12A	
<i>E2</i>	COURTESY LIGHT TIME	0	99	<i>EE</i> Courtesy light time adjustment <i>PP</i> Adjusting the pre-flashin light time	00	12A	
<i>E3</i>	FOLLOW ME	-	-	<i>EE</i> <i>00</i> Deactivates follow me <i>01</i> Activates follow me (fully open) <i>02</i> Activates follow me (in open or fully open position)	00	12B	
				1s 9s <i>En</i> Set closing time (sec)			03
<i>E4</i>	OPERATION MODE WITH BATTERIES	-	-	<i>00</i> Normal operation <i>01</i> Barrier opens and stays open <i>02</i> Barrier closes and remains closed	00	12B	
<i>E5</i>	ELECTRIC BRAKE	-	-	<i>00</i> Disabled <i>01</i> Low intensity <i>02</i> Medium intensity <i>03</i> High intensity	00	13A	
<i>E6</i>	SLOWDOWN SPEED	1	9	<i>S0</i> Adjusting the slowing down at the opening	01	13A	
		1	9	<i>S2</i> Adjusting the slowing down at the closing	01		
<i>E7</i>	MANUEVERS COUNTER	-	-	Shows the number of maneuvers performed	-	13B	
<i>E8</i>	RESET - RESTORE FACTORY SETTINGS	-	-	<i>00</i> Deactivated <i>01</i> Reset activated	00	13B	
<i>E9</i>	DOOR STATUS OUTPUT (Connector K)	-	-	<i>EE</i> <i>00</i> Continuous light <i>01</i> Flashing light	00	14A	
	BOOM LEDs (Connector I)	-	-	<i>HR</i> <i>00</i> Off   Fixed <i>01</i> Off   Intermittent <i>02</i> Fixed   Intermittent <i>03</i> Fixed   Fixed	02		
				<ul style="list-style-type: none"> <li>• To access the <b>E menu</b> press the MENU button for 8sec.</li> <li>• Use ↓ ↑ to navigate through the menus.</li> <li>• Press MENU when you want to confirm access to a menu.</li> <li>• Press ↓ ↑ simultaneously to exit programming.</li> </ul>			

## 04. PROGRAMMING



### PROGRAMMING "E"

E0 HUMAN PRESENCE/PUSHBUTTON			
<b>HP</b> Human presence  <b>When human presence active, the RF remote controls do not work.</b> For this menu to work, you must make the following configuration: E0 → PL → 01	00	<b>Disables human presence</b> Whenever an order is sent to the LO input and the barrier performs a complete maneuver	00 (Default value)
	01	<b>Active at closing</b> The motor only works if you keep the LS button pressed	
	02	<b>Active during opening and closing</b> The motor only works if you keep the LO or LS button pressed depending on the desired action	
PB Pushbutton	00	Disables pushbutton mode (LS: Partial opening   LO: Full opening)	00 (Default value)
	01	Active pushbutton mode (LS: Full closing   LO: Full opening)	
EB Allows you to define how the LB input works.	00	Disables LB input (Stop)	01 (Default value)
	01	Activates LB input (Stop)	
01 • Press MENU for 8 sec. until it appears E0. 02 • Press MENU until appears HP. Use UP or DW to navigate the parameters. 03 • Press MENU to edit the chosen parameter value. 04 • The factory set time appears. Use UP and DW to change the value. 05 • Press MENU to save the new value.			

## 04. PROGRAMMING

### PROGRAMMING "E"

E1 CALIBRATION	
This menu allows you to calibrate the barrier's course with the encoder when reaches the number of maneuvers selected for calibration.	
The range of maneuvers for calibration corresponds to the formula: <b>value selected in the function x 50 maneuvers.</b> <b>Example:</b> If the selected value is 3, it means that the calibration will be carried out every 150 maneuvers of the barrier (3x50= 150 maneuvers)	01 (Default value) 
01 • Press MENU for 8 sec. until it appears E0. 02 • Use UP until appears E1. 03 • Press MENU will appear 01. 04 • Press MENU to edit the value. 05 • Use UP and DW to change the value. 06 • Press MENU to save the new value.	

E2 COURTESY LIGHT TIME	
<b>LE</b> Courtesy light time Allows to adjust the courtesy light time. The courtesy light is activated the set time when the barrier is in the closed, opened and stopped position.	00min (Default value) 
<b>PE</b> Pre-flashing light time Allows you to adjust the pre-flashing light time. <b>If the value is 00 this function is deactivated.</b> The pre-flashing light is activated before an opening and closing maneuver, operating intermittently (0.5 sec).	00s (Default value) 
01 • Press MENU for 8 sec. until appears E0. 02 • Use UP to change to E2. 03 • Press MENU until appears LE. Use UP or DW to navigate the parameters. 04 • Press MENU to edit the chosen parameter value. 05 • The factory set time appears. Use UP and DW to change the value. 06 • Press MENU to save the new value.	

## 04. PROGRAMMING

### PROGRAMMING "E"

<b>E3 FOLLOW ME</b>		
<p><b>FE</b> This menu allows activating the Follow me option. With this function activated, whenever the safety device detects the passage of a user/object, the control board activates the closing maneuver based on the time selected in this parameter.</p>	<b>00</b> <b>Function disabled</b>	<p><b>00</b> (Default value)</p>
	<b>01</b> <b>Function activated after opening</b> The control board activates the closing only after completing the opening, based on the time defined in the <b>E7</b> function	
	<b>02</b> <b>Function activated during opening</b> The control board activates the closing after completing the opening, when, during opening, the user/object passes through the photocells, based on the time defined in the <b>E7</b> function	
<p><b>EE</b> <b>Closing time function</b> Allows you to define the waiting time between detection and the start of the closing maneuver after the safety device detects the passage of an object/user.</p>	<p><b>03s</b> (Default value)</p> 	
<p>01 • Press MENU for 8 sec. until <b>ED</b> appears. 02 • Use UP until appears <b>E3</b>. 03 • Press MENU will appear <b>EE</b>. 04 • Press MENU to edit the value. 05 • Use UP and DW to change the value. 06 • Press MENU to save the new value.</p>		

<b>E4 OPERATION MODE WITH BATTERIES</b>		
<p><b>E4</b> This menu allows you to define how the control board will operate on batteries in the event of a power failure.</p>		
<b>00</b> <b>Normal operation</b>	<p><b>00</b> (Default value)</p>	
<b>01</b> The barrier opens and remains open until power to the control board is restored.		
<b>02</b> The barrier closes and remains closed until power to the control board is restored.		
<p>01 • Press MENU for 8 sec. until <b>ED</b> appears. 02 • Use UP until appears <b>E4</b>. 03 • Press MENU will appear <b>00</b>. 04 • Press MENU to edit the value. 05 • Use UP and DW to change the value. 06 • Press MENU to save the new value.</p>		

## 04. PROGRAMMING

### PROGRAMMING "E"

<b>E5 ELECTRIC BRAKE</b>		
<p>Allows you to set the intensity of the electric brake.</p>		
<b>00</b> <b>Disabled</b>	<p><b>00</b> (Default value)</p>	
<b>01</b> <b>Low intensity</b>		
<b>02</b> <b>Medium intensity</b>		
<b>03</b> <b>High intensity</b>		
<p>01 • Press MENU for 8 sec. until it appears <b>ED</b>. 02 • Use UP until appears <b>E5</b>. 03 • Press MENU will appear <b>00</b>. 04 • Press MENU to edit the value. 05 • Use UP and DW to change the value. 06 • Press MENU to save the new value.</p>		

 The electric brake must be used on barriers with long booms, where the inertia is greater, requiring more effort to stop

<b>E6 SLOWDOWN SPEED</b>		
<p>This menu allows you to adjust the slowdown speed. The higher the level, the faster the slowdown.</p>		
<b>50</b> <b>Setting of the slowdown speed at the opening</b> Allows you to adjust the slowdown speed when opening.	<p><b>00</b> (Default value)</p> 	
<b>52</b> <b>Setting of the slowdown speed at the closing</b> Allows you to adjust the slowdown speed when closing.		
<p>01 • Press MENU for 8 sec. until it appears <b>ED</b>. 02 • Use UP until appears <b>E6</b>. 03 • Press MENU will appear <b>50</b>. 04 • Press MENU to edit the value. 05 • Use UP and DW to change the value. 06 • Press MENU to save the new value.</p>		

## 04. PROGRAMMING

### PROGRAMMING "E"

**E7 MANUEVERS COUNTER**  
This menu allows checking how many complete maneuvers were performed by the control board (complete maneuver means opening and closing).

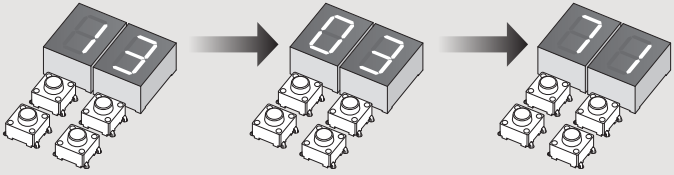

**Example:**  
130 371 maneuvers

1st Hundred thousand: 13  
2nd Thousands: 03  
3rd Dozens: 71

01 • Press MENU for 8 seconds.  
02 • *E0* appears. Press UP until appears *E7*.  
03 • Press MENU.  
04 • The maneuver count appears in the order shown above (example 130 371).  
05 • *E8* appears.

**E8 RESET - RESET FACTORY VALUES**

<i>00</i> Disabled	<i>00</i> (Default value)
<i>01</i> Reset enabled	

01 • Press MENU for 8 sec. until it appears *E0*.  
02 • Use UP until appears *E8*.  
03 • Press MENU will appear *00*.  
04 • Press MENU to edit the value.  
05 • Use UP and DW to change the value.  
06 • Press MENU to save the new value.



Resetting the control board does not erase the maneuver count.

## 04. PROGRAMMING

### PROGRAMMING "E"

**E9 DOOR STATUS OUTPUT/BOOM LEDS**

<b>Door status output</b> <i>E8</i> Allows you to change the way this output will act. (K connector outputs)	<i>00</i> Continuous light	<i>00</i> (Default value)
	<i>01</i> Flashing light	
<b>Boom LEDs operating mode</b> <i>HA</i> Allows you to change the way this output will act. (K connector outputs)	<i>00</i> Boom stopped: <b>Off</b> Moving boom: <b>Fixed</b>	<i>02</i> (Default value)
	<i>01</i> Boom stopped: <b>Off</b> Moving boom: <b>Intermittent</b>	
	<i>02</i> Boom stopped: <b>Fixed</b> Moving boom: <b>Intermittent</b>	
	<i>03</i> Boom stopped: <b>Fixed</b> Moving boom: <b>Fixed</b>	

01 • Press MENU for 8 sec. until it appears *E0*.  
02 • Use UP until appears *E9*.  
03 • Press MENU will appear *E8*.  
04 • Use UP and DW to navigate the parameters.  
05 • Press MENU to select the parameter.  
06 • Use UP and DW to change the value.  
07 • Press MENU to save the new value.

## 05. DISPLAY

### DISPLAY INDICATIONS

MENU	DESCRIPTION
00	In stop position, fully open
01	In stop position, intermediate position
02	In stop position, fully closed
03	Full opening button pressed
04	Pedestrian opening button pressed
05	Control board performs the opening course
06	Control board performs the closing course
07	End of opening course time
08	End of closing course time
09	Full memory
10	All remote controls erased
00 01 02	Remote control triggered from the indicated position
11	Obstructed photocell
12	Obstructed photocell
13	In pause time
14	In pedestrian pause time
15	Obstacle detection
16	Emergency device activated
17	Safety edge pressed

MENU	DESCRIPTION
18	Processing error
19	Overvoltage error
20	Under voltage error
21	Startup error
22	Encoder error
23	EEPROM memory error
24	Motor phase missing error
25	Photocell test failed
26	Control board in Pre-Flashing lamp
27	Motor overcurrent detection

# 06. CONNECTION DIAGRAM

## BARRIER

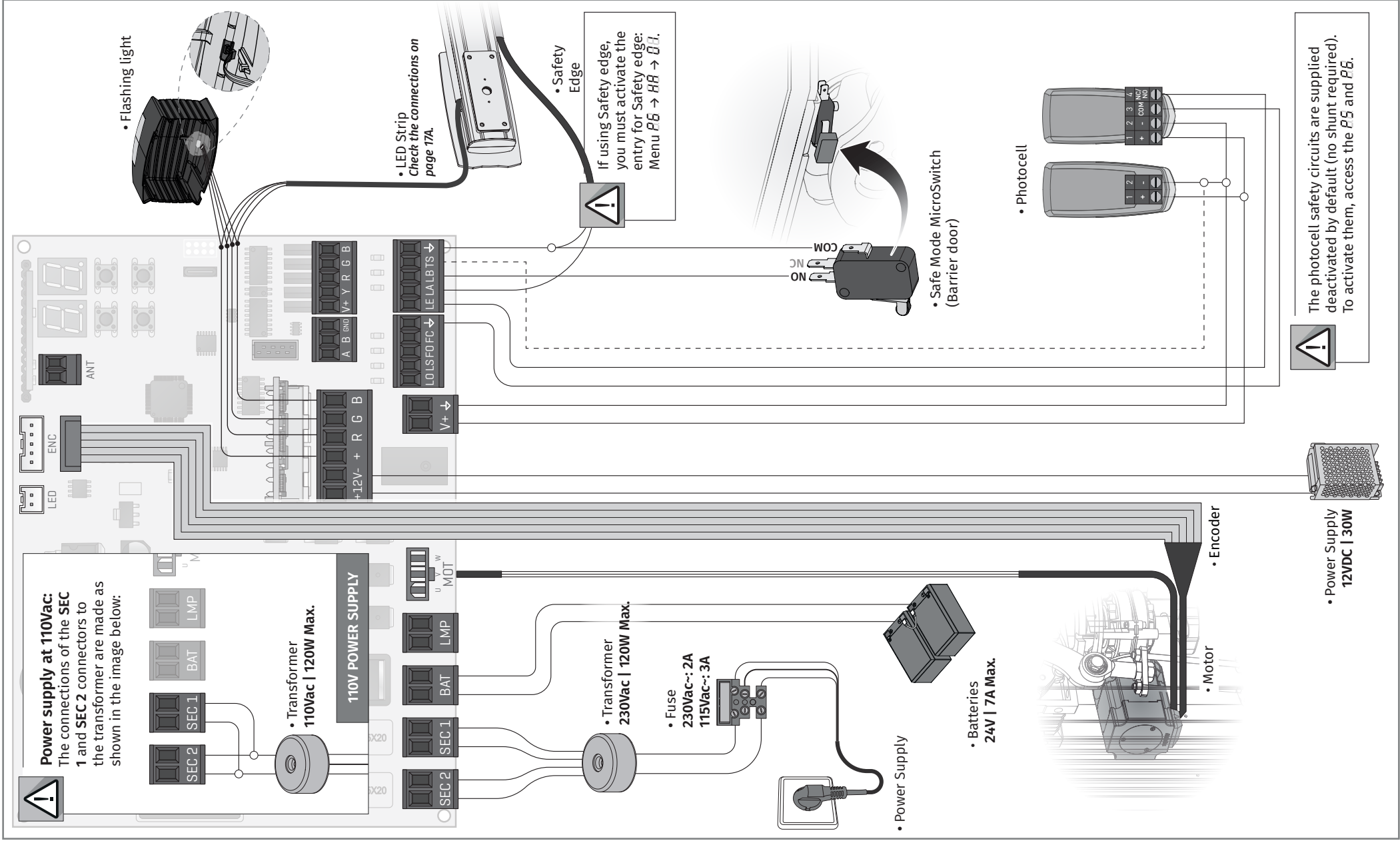

## 06. CONNECTION DIAGRAM

### MM90-RGB MODULE

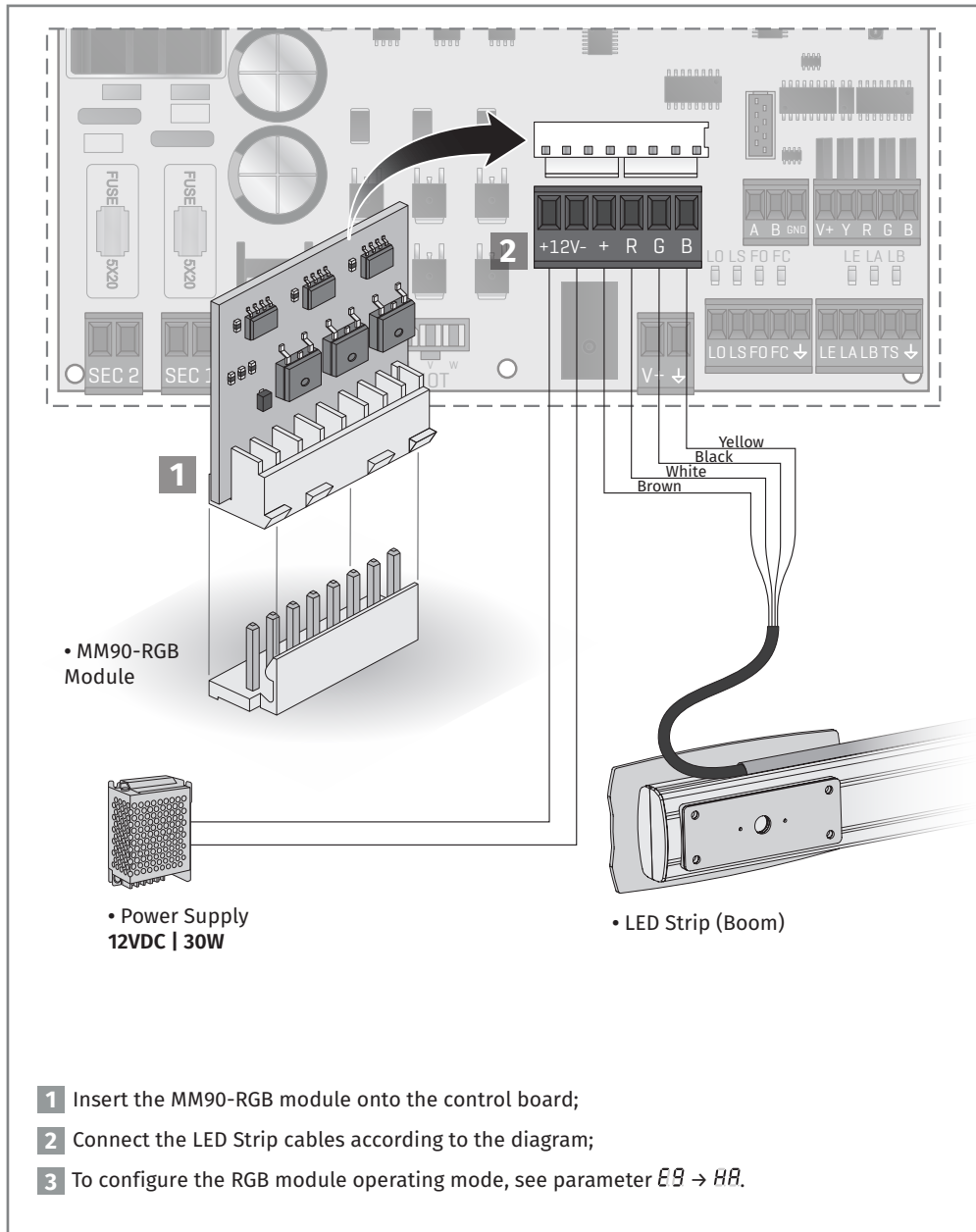

## 06. CONNECTION DIAGRAM

### MASTER / SLAVE (OPTIONAL)

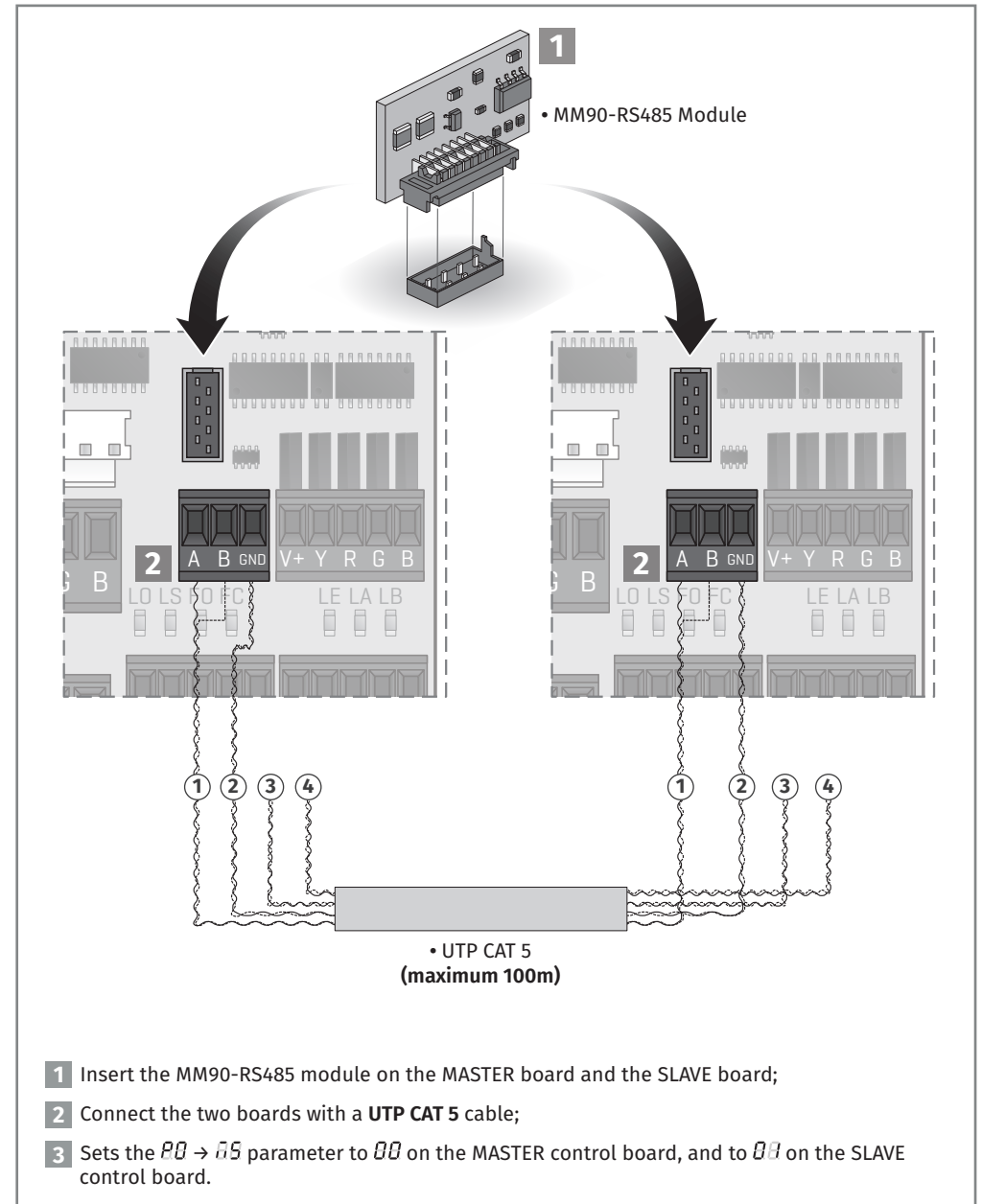

# 07. TROUBLESHOOTING

## INSTRUCTIONS FOR FINAL CONSUMERS/TECHNICIANS

Anomaly	Procedure	Behavior	Procedure II	Discovering the origin of the problem
• Motor doesn't work.	• Make sure you have power supply connected to the automatism and if it is working.	• Still not working.	• Consult a MOTORLINE technician.	<ol style="list-style-type: none"> <li>1 • Open control board and check if it has power supply.</li> <li>2 • Check input fuses of the control board.</li> <li>3 • If the motor works, the problem is on the control board. Pull it out and send it to our MOTORLINE technical services for diagnosis.</li> <li>4 • If the motor doesn't work, remove from installation site and send it to our MOTORLINE technical services for diagnosis.</li> </ol>
• Motor doesn't move but makes noise.	• Unlock the motor and move the barrier by hand to check for mechanical problems.	• Encountered problems?	• Consult a qualified technician in barriers.	Check all motion axis and associated motion systems related with the barrier to find out what is the problem.
		• The barrier moves easily?	• Consult a MOTORLINE technician.	<ol style="list-style-type: none"> <li>1 • If the motor works, the problem is with control board. Pull it out and send it to our MOTORLINE technical services for diagnosis.</li> <li>2 • If the motor doesn't work, remove it from installation site and send it to our MOTORLINE technical services for diagnosis.</li> </ol>
• Motor opens but doesn't close.	• Unlock the motor and move the barrier by hand to closed position. Block the motor again. Turn off power supply for 5 seconds, and reconnect. Send order to open using remote control.	• The barrier opened but didn't close again.	<ol style="list-style-type: none"> <li>1 • Check if there is any obstacle in front of the photocells.</li> <li>2 • Check if any of the control devices (Key Selector, Pushbutton, Video Intercom, etc.) are stucked and sending permanent signal to control board.</li> <li>3 • Consult a MOTORLINE technician.</li> </ol>	<p>All control boards MOTORLINE have LEDs that easily allow to conclude which devices are with anomalies. All safety device (DS) LEDs in normal situations remain ON. All "START" circuits LEDs in normal situations remain Off. If LEDs devices are not all On, there is some security systems malfunction (photocells, safety edges). If "START" LEDs are on, there is some remote control device emitting a permanent signal.</p> <p><b>A) SECURITY SYSTEMS:</b></p> <ol style="list-style-type: none"> <li>1 • Close with a shunt all safety systems on the control board. If the automated system starts working normally check for the problematic device.</li> <li>2 • Remove one shunt at a time until you find the malfunction device.</li> <li>3 • Replace it for a functional device and check if the automation works correctly with all the other devices. If you find another one defective, follow the same steps until you find all the problems.</li> </ol> <p><b>B) START SYSTEMS:</b></p> <ol style="list-style-type: none"> <li>1 • Disconnect all wires connected to the START connector (LO and LS).</li> <li>2 • If the LED turned OFF, try reconnecting one device at a time until you find the defective device.</li> </ol> <p><b>NOTE:</b> In case procedures described in sections A) and B) don't result, remove control board and send it to our MOTORLINE technical services for diagnosis.</p>
• Motor doesn't make complete course.	• Unlock the motor and move the barrier by hand to check for mechanical problems.	• Encountered problems?	• Consult a qualified technician in barriers.	Check all motion axis and associated motion systems related with the barrier to find out what is the problem.
		• The barrier moves easily?	• Consult a MOTORLINE technician.	<ol style="list-style-type: none"> <li>1 • If the motor doesn't work, remove it from installation site and send it to our MOTORLINE technical services for diagnosis.</li> <li>2 • If the motor works well and move the boom at full force during the entire course, the problem is with control board. Set force using trimmer on the board. Make a new working time programming, giving enough time for opening and closing with appropriate force.</li> <li>3 • If this doesn't work, remove control board and send it to MOTORLINE technical services.</li> </ol> <p><b>NOTE:</b> Setting force of the control board should be sufficient to make the barrier open and close without stopping, but should stop and invert with a little effort from a person. In case of safety systems failure, the barrier shall never cause physical damaged to obstacles (vehicles, people, etc.).</p>