



TELICA

USER'S AND INSTALLER'S MANUAL



00. CONTENT

INDEX

01. SAFETY INSTRUCTIONS	
STANDARDS TO FOLLOW	1B
02. THE PACKAGE	
INSIDE THE PACKAGE	3A
03. OPERATOR	
DIMENSIONS	3B
TECHNICAL SPECIFICATIONS	3B
04. INSTALLATION	
EMERGENCY UNLOCK	4A
EXTERNAL UNLOCK	4A
INSTALLATION MEASURES	4B
SUPPORTS INSTALLATION	4B
AUTOMATISM INSTALLATION	5A
ARMS INSTALLATION	5A
MICROS ADJUSTMENT	5B
05. TROUBLESHOOTING	
INSTRUCTIONS FOR FINAL CONSUMERS	6A
INSTRUCTIONS FOR SPECIALIZED INSTALLERS	6B
06. COMPONENTS TEST	
230Vac MOTOR	7A
24Vdc MOTOR	7B
07. CONNECTION SCHEME	
230V/110V MOTOR (MC2)	8A
24V MOTOR (MC11)	9B

01. SAFETY INSTRUCTIONS

STANDARDS TO FOLLOW

ATTENTION:



This product is certified in accordance with European Community (EC) safety standards.



This product complies with Directive 2011/65/EU of the European Parliament and of the Council, of 8 June 2011, on the restriction of the use of certain hazardous substances in electrical and electronic equipment.



(Applicable in countries with recycling systems).
This marking on the product or literature indicates that the product and electronic accessories (eg. Charger, USB cable, electronic material, controls, etc.) should not be disposed of as other household waste at the end of its useful life. To avoid possible harm to the environment or human health resulting from the uncontrolled disposal of waste, separate these items from other types of waste and recycle them responsibly to promote the sustainable reuse of material resources. Home users should contact the dealer where they purchased this product or the National Environment Agency for details on where and how they can take these items for environmentally safe recycling. Business users should contact their vendor and check the terms and conditions of the purchase agreement. This product and its electronic accessories should not be mixed with other commercial waste.



This marking indicates that the product and electronic accessories (eg. charger, USB cable, electronic material, controls, etc.) are susceptible to electric shock by direct or indirect contact with electricity. Be cautious when handling the product and observe all safety procedures in this manual.

01. SAFETY INSTRUCTIONS

STANDARDS TO FOLLOW

- It is important for your safety that these instructions are followed.
- Keep these instructions in a safe place for future reference.
- The **ELECTROCELOS S.A.** is not responsible for the improper use of the product, or other use than that for which it was designed.
- The **ELECTROCELOS S.A.** is not responsible if safety standards were not taken into account when installing the equipment, or for any deformation that may occur.
- The **ELECTROCELOS S.A.** is not responsible for insecurity and malfunction of the product when used with components that were not sold by the them.
- This product was designed and manufactured strictly for the use indicated in this manual.
- Any other use not expressly indicated may damage the product and/or can cause physical and property damages, and will void the warranty.
- Do not make any changes to the automation components and/or their accessories.
- Keep remote controls away from children, to prevent the automated system from being activated involuntarily.
- The customer shall not, under any circumstances, attempt to repair or tune the automatism. Must call qualified technician only.
- The installer must have certified professional knowledge at the level of mechanical assemblies in doors and gates and control board programming. He should also be able to perform electrical connections in compliance with all applicable regulations.
- The installer should inform the customer how to handle the product in an emergency and provide him the manual.
- This device can be used by children 8 year old or older and persons whose physical, sensory or mental capacities are reduced, or by persons without experience or knowledge if they have received supervision or instructions on the use of the device in a safe manner and understood the hazards involved. Children should not play with the device. Cleaning and maintenance by the user must not be carried out by unsupervised children.
- Automatism powered by very low safety voltage, with electronic board / control board / control unit. **(24 Vdc)**
- Before installing, the installer must verify that the temperature range indicated on the automatism is appropriate to the location of the installation.
- Before installing, the installer must verify that the equipment to be automated is in good mechanical condition, correctly balanced and opens and closes

01. SAFETY INSTRUCTIONS

STANDARDS TO FOLLOW

- properly.
- If the automation is to be installed at a level higher than 2,5 m above ground level or other level of access, , should be followed the minimum safety and health requirements for the use of work equipment workers at work in Directive 2009/104/EC of the European Parliament and of the Council of 16th September of 2009.
- In the case of the equipment where the automation will be installed, have a pedestrian door, be aware that it must be closed when the automation is activated.
- After installation, make sure that the mechanism is properly adjusted and that the protection system and any manual unlocker works correctly.
- In order to protect the electrical cables against mechanical stress, you should use conduit for the electrical wires, essentially on the power cable.
- When programming the control unit on the control board, you should pay particular attention to touching only the location intended for that purpose. Failure to do so may result in electric shock.

02. THE PACKAGE

INSIDE THE PACKAGE

Components on the 2 motor's package:

- 01 • 02 articulated motors
- 02a • 01 articulated right arm
- 02b • 01 articulated left arm
- 03 • 02 4 channels remote controls
- 04 • 02 frontal supports
- 05 • 02 motor supports
- 06 • 02 unlock keys
- 07 • 01 photocells set
- 08 • 01 user manual

Components on the 1 motor's package:

- 01 • 01 articulated motor
- 02a • 01 articulated direito/esquerdo arm
- 03 • 02 4 channels remote controls
- 04 • 01 frontal support
- 05 • 01 motor's support
- 06 • 01 unlock key
- 07 • 01 photocells set
- 08 • 01 user manual

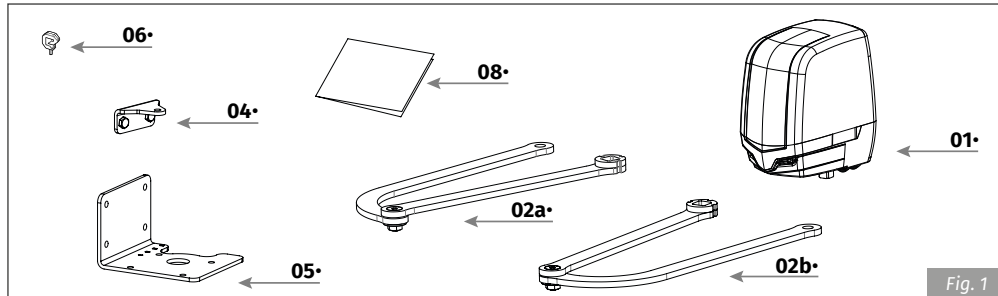

Fig. 1

Kit components:



Fig. 2

Kit package:

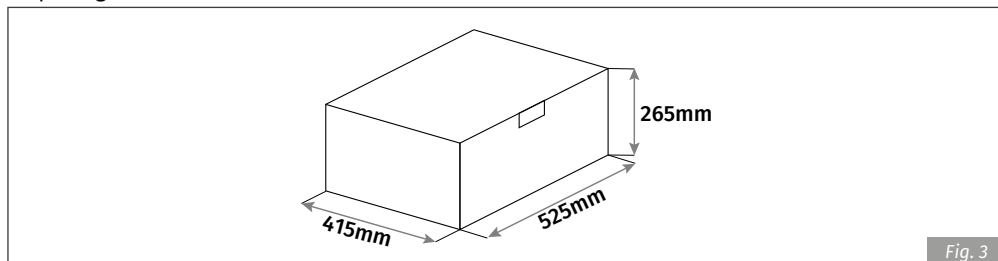

Fig. 3

03. OPERATOR

DIMENSIONS

The dimensions of the **TELICA** automation are the following:

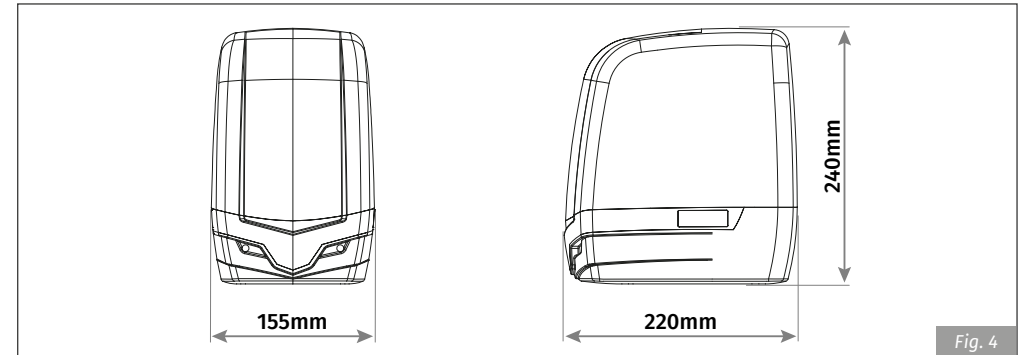

Fig. 4

TECHNICAL SPECIFICATIONS

	24Vdc	230Vac
• Power supply	24Vdc	230Vac
• Power	220W	380W
• Force	200 Nm	200 Nm
• Working frequency	Intensive Use	50 %
• Capacitor	-	12,5 µF
• Protection grade	IP53	IP53
• Noise	LpA <= 50dB (A)	LpA <= 50dB (A)
• Thermal protection	-	120° C
• Operating temperature	-25° C to 55° C	-25° C to 55° C
• RPM	1,30 RPM	1,10 RPM



This automation is suitable for leaves up to 2.5 meters wide. For leaves with a width higher than 2,50 meters, we recommend the use of an electric lock.

04. INSTALLATION

EMERGENCY UNLOCK



The emergency unlock should only be used in case of emergency, electrical failure or malfunction.

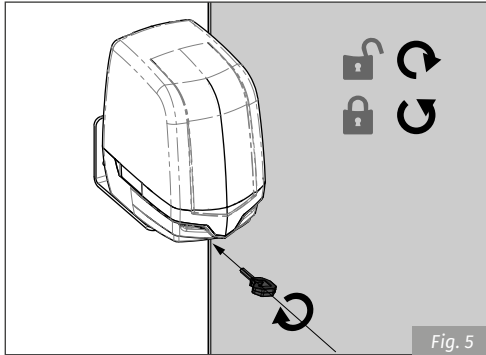

To unlock...
insert the unlock key into the automation front hole and turn it on clockwise 4-5 times until you feel a limit.

To lock...
Rode a chave no sentido contrário até sentir um obstáculo.

EXTERNAL UNLOCK



The kit exemplified below is not included in the **TELICA Kit**.

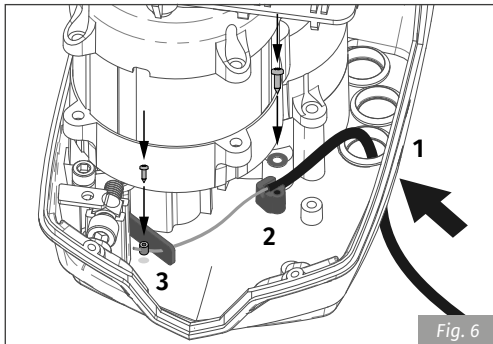

- 1 • Pass the cable into the **TELICA** through the cable gland.
- 2 • Place the cable sleeve in the indicated location and fix it with a washer and a screw.
- 3 • Pass the steel cable through the hole in the trigger and fix it with an end-fixing. Cut the excess.

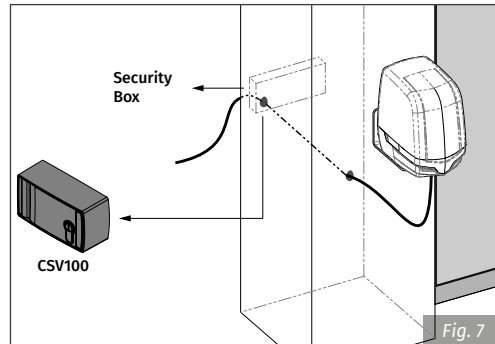

The cable can then be connected to a security box as in **fig. 7** to allow external unlocking.

04. INSTALLATION

INSTALLATION MEASURES

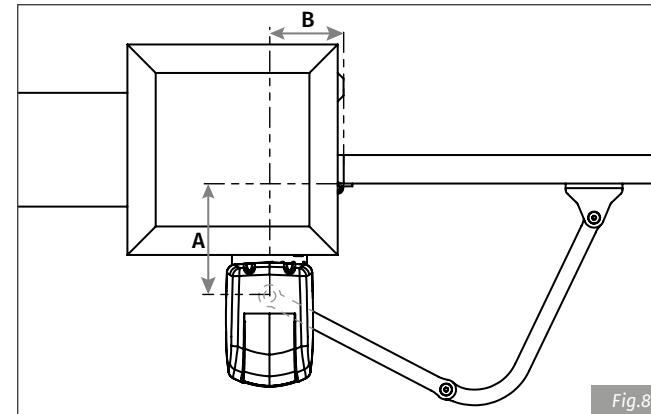

The table below indicates the measure which quota **B** should have in function of the quota **A** measure.

QUOTA A	QUOTA B
máx. 350 mm	170 a 210 mm
300 mm	120 a 220 mm
250 mm	110 a 250 mm
200 mm	100 a 250 mm
150 mm	100 a 250 mm
mín. 100 mm	100 a 270 mm

QUOTA A • Vertical distance between the center of the hinge and the center of the motor shaft.

QUOTA B • Horizontal distance between the center of the hinge and the center of the motor shaft.

SUPPORTS INSTALLATION

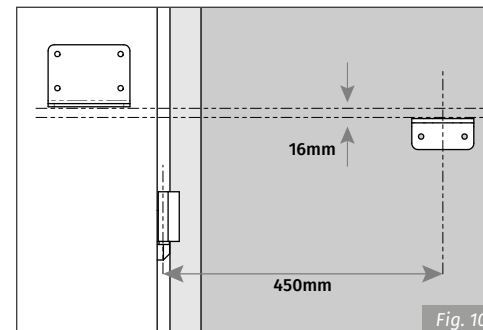
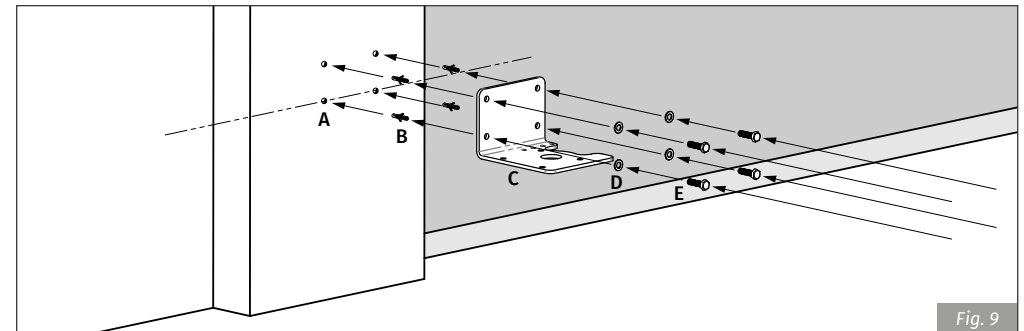

- 1 • Drill holes for M8 screw anchors.
- You must use appropriate anchorages for the type of surface where the automation will be installed.
- 2 • Place the anchors in the holes, press the plate against the wall and fix it with the appropriate screws.
- 3 • Attach the front support to the door leaf, following the dimensions of **Fig. 10**. • 450mm from the door hinge and 19mm below the motor support.



Use M8 bolts for fixing the supports.

04. INSTALLATION

AUTOMATISM INSTALLATION

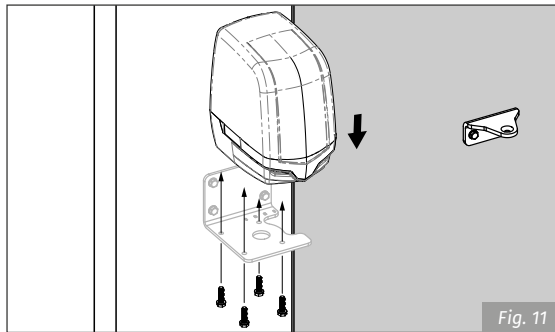

1 • Place the motor on the support plate and fix it with supplied M8 screws.

ARMS INSTALLATION

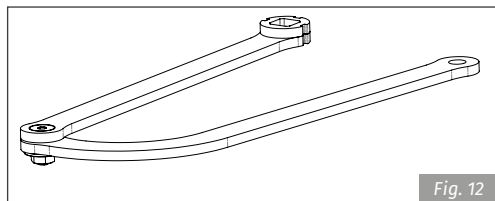

The arms are supplied already assembled.
• If you install only one motor and the arm is not in the correct position, you can easily change the direction following the indications in the picture Fig. 13.

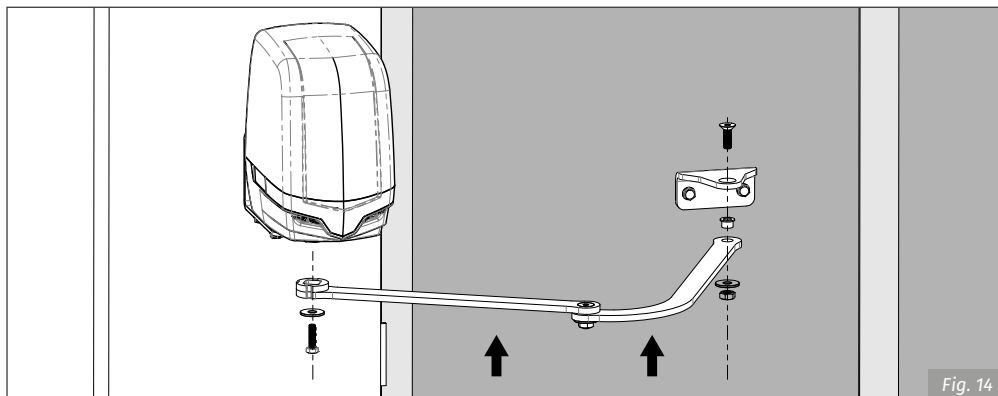
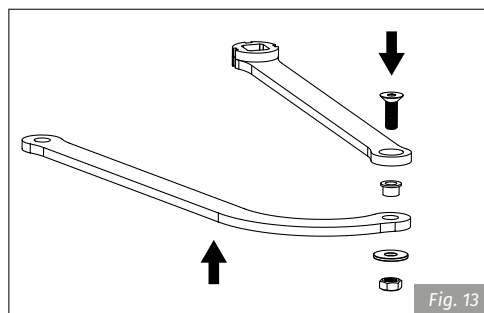

1 • Mount the square hole in the motor's output shaft, and tighten with provided washer and M10x20 screw. 2 • Place the other extremity of the arm under the gate support, and secure with screw, bushing, washer, and female.

04. INSTALLATION

MICROS ADJUSTMENT

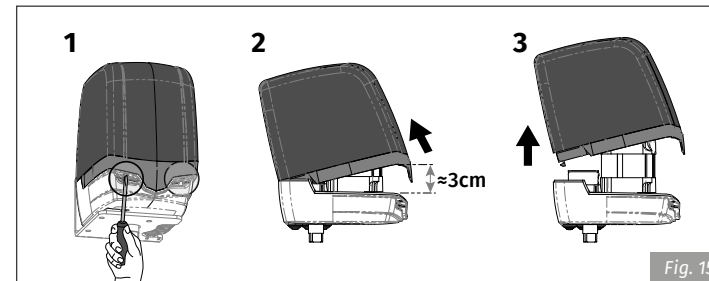

Remove the automation's cover. To do this, loosen the two front screws, slightly tilt the cover back and pull up.

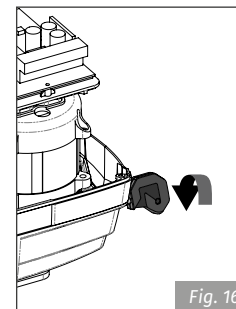

1 • Unlock the automation and open the door leaf to the desired position.

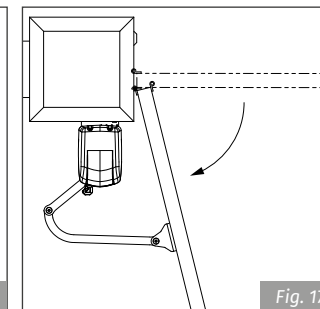

2 • Loosen (A) the opening ring screw, and turn it (B) until you hear a *click* of the micro switch.



3 • Tighten the screw (C) of the ring to lock it in this position.

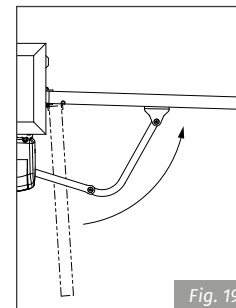

4 • Close the door leaf, loosen (A) and turn (B) the closing ring until it makes a *click* into the corresponding micro. Retighten (C) the ring screw.

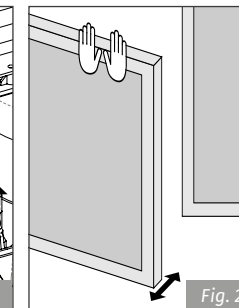
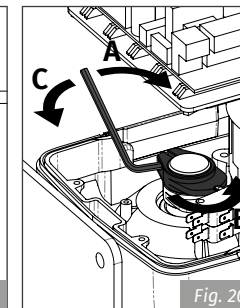

5 • Manually test the opening and closing of the gate to ensure that the micro switches are activated in the correct point. 6 • When the micros are tuned, re-lock the automation.

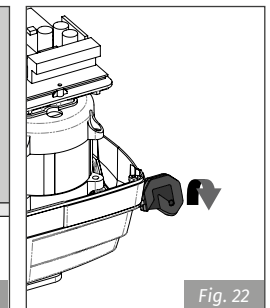

After the installation is complete, make all the electrical connections and replace the cover.

05. TROUBLESHOOTING

INSTRUCTIONS FOR FINAL CONSUMERS

INSTRUCTIONS FOR SPECIALIZED INSTALLERS

Anomaly	Procedure	Behavior	Procedure II	Discovering the origin of the problem
• Motor doesn't work at all	• Make sure you have 230Vac/24Vdc power in the automation control board and if it is working properly.	• Still not working	• Consult a qualified MOTORLINE technician.	<ol style="list-style-type: none"> 1 • Open control box and check if it has 230Vac/24Vdc power supply; 2 • Check input fuses; 3 • Disconnect motor from control board and test it by connecting directly to power supply in order to find out if it has problems (see page 07A/07B) 4 • If the motor work, the problem is on the control board. Pull it out and send it to our MOTORLINE technical services for diagnosis; 5 • If the motor doesn't work, remove it from installation site and send to our MOTORLINE technical services for diagnosis.
• Motor doesn't move but makes noise	• Unlock motor and move gate by hand to check for mechanical problems on the gate.	Did you find problems?	• Consult an experienced gate expert.	1 • Check all motion axis and associated motion systems related with gate and operators (pins, hinges, etc.) to find out what is the problem.
		• Gate moves easily?	• Consult a qualified MOTORLINE technician.	<ol style="list-style-type: none"> 1 • Disconnect motor from control board and test it by connecting directly to power supply in order to find out if it has problems (see page 07A/07B) 2 • If the motor work, the problem is on the control board. Pull it out and send it to our MOTORLINE technical services for diagnosis; 3 • If the motor doesn't work, remove it from installation site and send to our MOTORLINE technical services for diagnosis.
• Motor opens but doesn't close	• Unlock motor and move gate by hand to closed position. Lock motor(s) again and turn off power supply for 5 seconds. Reconnect it and send order to open gate using transmitter.	• Gate opened but didn't close again.	<ol style="list-style-type: none"> 1 • Check if there is any obstacle in front of the photocells; 2 • Check if any of the control devices (key selector, push button, video intercom, etc.) of the gate are jammed and sending permanent signal to control unit; 3 • Consult a qualified MOTORLINE technician. 	<p>TALL MOTORLINE control boards have LEDs that easily allow to conclude which devices are with anomalies. All safety devices LEDs (DS) in normal situations remain On. All "START" circuits LEDs in normal situations remain Off.</p> <p>If LEDs devices are not all On, there is some security systems malfunction (photocells, safety edges), etc. If "START" circuits LEDs are turn On, there is a control device sending permanent signal.</p> <p>A) SECURITY SYSTEMS:</p> <ol style="list-style-type: none"> 1 • Close with a shunt all safety systems on the control board (check manual of the control board in question). If the automated system starts working normally check for the problematic device. 2 • Remove one shunt at a time until you find the malfunction device . 3 • Replace it for a functional device and check if the operator works correctly with all the other devices. If you find another one defective, follow the same steps until you find all the problems. <p>B) START SYSTEMS:</p> <ol style="list-style-type: none"> 1 • Disconnect all wires from START terminal input. 2 • If the LED turned Off, try reconnecting one device at a time until you find the defective device. <p>NOTE: If the procedures described in sections A) and B) don't result, remove control board and send to our technical services for diagnosis.</p>
• Motor doesn't make complete route	• Unlock motor and move gate by hand to check for mechanical problems on the gate.	• Encountered problems?	• Consult an experienced gate expert	1 • Check all motion axis and associated motion systems related with gate and operators (pins, hinges, etc.) to find out what is the problem.
		• Gate moves easily?	• Consult a qualified MOTORLINE technician.	<ol style="list-style-type: none"> 1 • Check if the limit microswitches are adjusted for the required course. 2 • Disconnect motor from control board and test it by connecting directly to power supply in order to find out if it has problems (see page 07A/07B) 3 • If the motor doesn't work, remove it from installation site and send to our MOTORLINE technical services for diagnosis. 4 • If motors work well and move gate at full force during the entire course, the problem is from controller. Set force using trimmer on the board. Make a new working time programming , giving sufficient time for opening and closing with appropriate force (see manual of the controller in question). <p>NOTA: Setting force of the controller should be sufficient to make the gate open and close without stopping, but should stop with a little effort from a person. In case of safety systems failure, the gate shall never cause physical damaged to obstacles (vehicles, people, etc.).</p>

06. COMPONENTS TEST

230Vac MOTOR

To detect if the malfunction is on the control board or on the motor is, sometimes, necessary to perform tests with connection directly to a 230Vac power supply.

For this, it is necessary to interpose a capacitor on the connection in order to the automatism to work (check the type of capacitor to be used in the product manual).

The diagram below, shows how to make that connection and how to merge the different components wires.



NOTES:

- To perform the tests, there is no need to remove the automatism from the place it is installed, because in this way, it is possible to understand if the automatism can function properly connected directly to the current.
- You should use a new capacitor during this test to ensure that the problem does not lie on it.

- 1 • Connect the power wires to the terminal, as shown below.
- 2 • Connect the automatism wires in the terminal, interposing a capacitor in the opening and closing wires.
- 3 • Once these connections are completed, connect to a 230Vac power outlet, depending on the motor / control board in test.

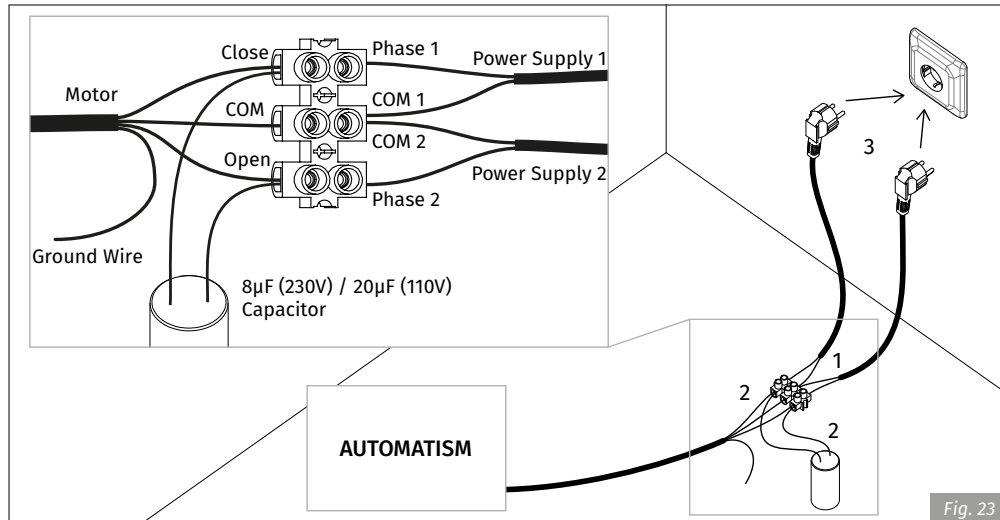

All tests must be performed by qualified personnel due to serious danger associated with the misuse of electrical systems!

06. COMPONENTS TEST

24Vdc MOTOR

To detect which are the components with problems in a **24Vdc TELICA** automatism installation, it's sometimes necessary to run a test directly to a external power supply (another 24Vdc battery).

The diagram below shows how to connect the motor to the battery.



NOTES:

- To make these tests it isn't necessary to remove it from the location where it is installed, because in this way, you can understand of the automatism works properly directly connected to the external battery.
- Once you connect the wires to a battery 24V, the motor must work for one direction. To test the opposite movement, change the position of the wires connected to the battery.

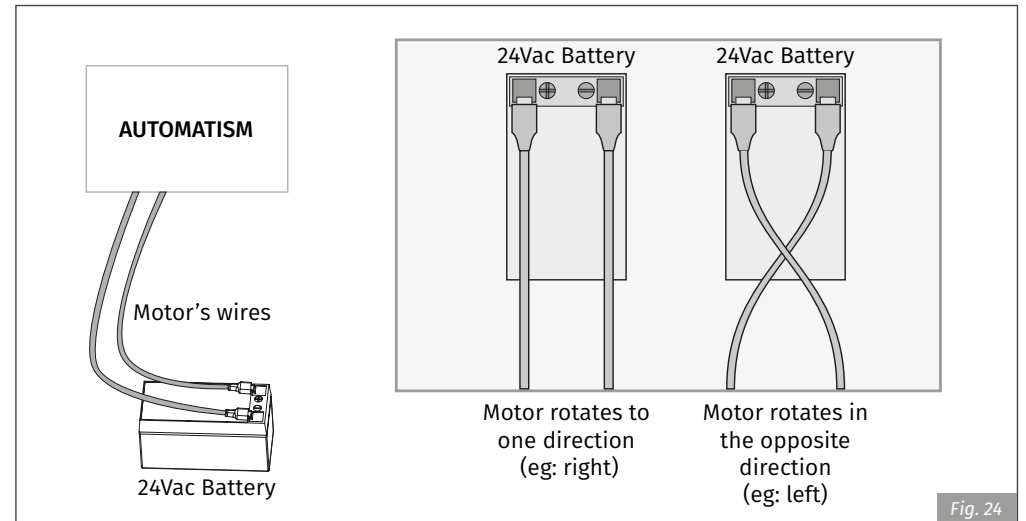

All tests must be performed by qualified personnel due to serious danger associated with the misuse of electrical systems!

07. CONNECTION SCHEME

230V/110V MOTOR (MC2)

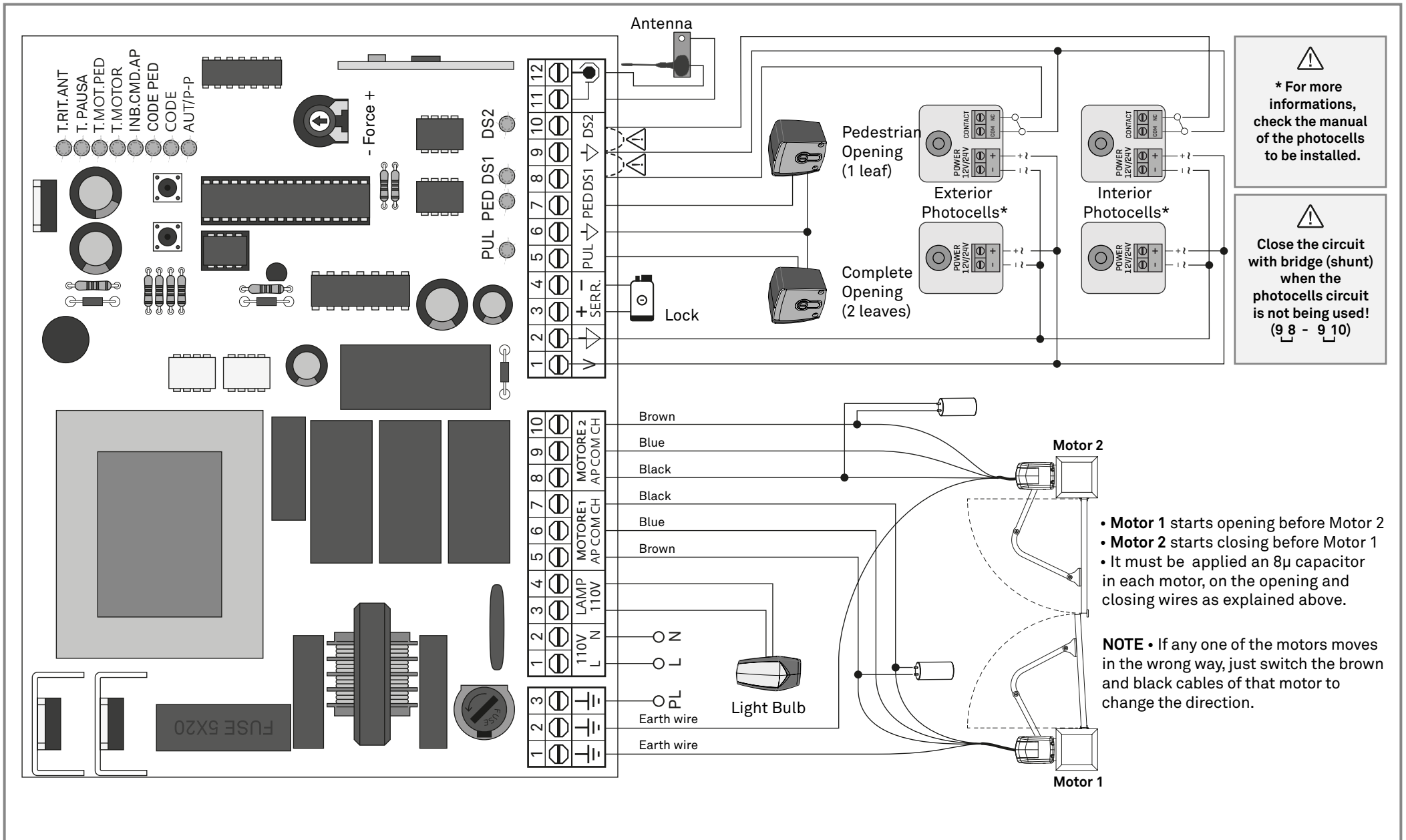

07. CONNECTION SCHEME

24V MOTOR (MC11)

